

DESCRIPTION	PAGE NO.
Basic Hydraulic Formulas	TD1
Ratings and Testing	TD1
Temperature Ratings	TD1
Viscosity	TD1
Pressure Ratings	TD1
Thermal Shock	TD1
Service and Components	TD1
Limitations in Use	TD1
Seal Material Selection	TD2
Hydraulic Fluids	TD3
Hydraulic Filtration	TD3
Application of Product	TD3
Offer of Sale	TD4

CV

Check
Valves

SH

Shuttle
Valves

LM

Load/Motor
Controls

FC

Flow
Controls

PC

Pressure
Controls

LE

Logic
Elements

DC

Directional
Controls

MV

Manual
Valves

SV

Solenoid
Valves

PV

Proportional
Valves

CE

Coils &
Electronics

BC

Bodies &
Cavities

TD

Technical
Data

CV

Check
Valves

INTRODUCTION

In this section you will find a variety of technical information pertinent to general hydraulics as well as cartridge valve technology.

SH

Shuttle
Valves

HYDRAULIC FORMULAS

Below are a few of the common hydraulic formulas to assist you in calculating the requirements for your system:

$$\text{Voltage} = \text{Current} \times \text{Resistance}$$

$$\text{Flow} = \text{Volume} \div \text{Unit of Time}$$

$$\text{Pressure} = \text{Force} \div \text{Area}$$

$$\text{Horsepower} = \text{Flow} \times \text{Pressure} \div (1714 \times \text{Efficiency})$$

$$\text{Hydraulic power (kW)} = \frac{\Delta p \text{ (Bar)} \times \text{flow rate (LPM)}}{600}$$

where Δp = pressure drop

$$\text{Hydraulic power (HP)} = \frac{\Delta p \text{ (PSI)} \times \text{flow rate (GPM)}}{1714}$$

FC

Flow
Controls

PC

Pressure
Controls

LE

Logic
Elements

RATINGS & TESTING

All Parker cartridge valve products have been performance tested with the results shown on the individual valve catalog pages. The performance data shown represents typical operation characteristics of the product. In addition, our valves are endurance tested. Validation is conducted by testing or similarity in designs.

Note: Not every cartridge option is endurance tested. In other words, one three way spool is endurance tested, and the others are assumed by similarity.

DC

Directional
Controls

MV

Manual
Valves

SV

Solenoid
Valves

TEMPERATURE RATINGS

Product operating limits are broadly in the range -30°C to 150°C (-20°F to 300°F) but satisfactory operation within the specification may not be accomplished. Leakage and response will be affected when used at temperature extremes and it is the user's responsibility to determine acceptability at these levels.

PV

Proportional
Valves

CE

Coils &
Electronics

Seals used in these products generally have the following temperature limitations:

Nitrile (Buna N) -30°C to 100°C (-20°F to 210°F)

Fluorocarbon -20°C to 150°C (-4°F to 300°F)

Hytrel -54°C to 135°C (-65°F to 275°F)

GTPFE -30°C to 150°C (-20°F to 300°F)

BC

Bodies &
Cavities

TD

Technical
Data

VISCOSITY

Catalog data is from tests conducted on mineral oil at a viscosity of 30 cSt (140 SSU) using an ISO VG:46 test fluid.

Product should ideally be used at viscosities in the range of 15 to 50 cSt (80 to 230 SSU).

Product will perform with reduced efficiency in the ranges, 5 to 15 cSt (42 to 80 SSU) and 50 to 500 cSt (230 to 2300 SSU). These extreme conditions must be evaluated by the user to establish suitability of the product's performance.

PRESSURE RATINGS

Unless otherwise stated, all Parker cartridges have a continuous duty pressure ratings as shown in the catalog. All pressure ratings are based on the cartridge valve only. Exposure to elevated pressures may affect the performance and fatigue life of the product. The material chosen for the body or carrier may affect the pressure rating we recommend. Parker does not recommend the use of cartridge valves in aluminum bodies at pressures above 207 bar (3000 psi).

THERMAL SHOCK

It is unreasonable to expect product to withstand rapid temperature changes - this could affect both performance and life and care should be taken to protect the product from such situations.

SERVICE & COMPONENTS

One of the advantages of integrated hydraulic circuits is their serviceability. Should a valve need to be replaced for any reason, a user only needs to unscrew the valve from the manifold and screw the replacement into the cavity. As such, there are few replacement parts available for the Parker cartridge products. As with any hydraulic system, the operator should bleed off any trapped pressure and consult machine service manuals prior to service. Parker does not offer any service parts for internal components, but external components such as coils, knobs, and seals are available.

LIMITATIONS IN USE

Parker cartridge valves are designed for a wide variety of industrial and mobile applications. Despite their flexibility, Parker Hannifin does not recommend or support the use of our cartridge valves in any on highway or aerospace applications. We also do not recommend our products for use in the transport of explosive products or in hazardous environments.

SEAL MATERIAL SELECTION

You should match the seal compatibility to the temperature and fluid being used in your application. Parker offers three seal materials to meet your application requirements. Parker's standard material is a 4301 Polyurethane RESILON™ material "D"-Ring. We also offer Fluorocarbon and Nitrile seals. A brief synopsis of each seal material is given below to help you choose the best seal for your application.

"D"-Ring (4301 Polyurethane RESILON™ Material)

The "D"-Ring is the standard seal material on the Winner's Circle threaded cartridge valves. The "D"-Ring is molded of a special 4301 Polyurethane RESILON™. Polyurethane materials exhibit better wear resistance and tensile strength than standard Nitrile or Fluorocarbon material. In addition, it has an excellent resistance to compression set. This increased strength eliminates the need for back-rings and simplifies installation.

The 4301 compound is a Parker exclusive material designed to prevent hydrolysis at high temperatures.

Thus, the "D"-Ring outperforms standard polyurethane o-rings, especially when using high water content fluids at elevated temperatures. The "D"-Ring is compatible with most water-glycol, water/oil emulsions, and high grade petroleum based hydraulic fluids at temperatures between -45°C to +93°C (-50°F to +200°F)

The unique shape of the Parker "D"-Ring also provides a variety of design advantages. The seal is molded into a "D" shape where the seal is higher in the middle and lower on the ends. This prevents the seal edge from folding over on a corner inside the manifold during installation. In addition, this design has a minimal lip, thus, friction is reduced. Another unique feature of the "D"-Ring is its symmetrical design, resulting in no performance degradation from the reverse direction, or worry of backward installation. The "D"-Ring is also equipped with "pressure pedestals" to reduce the effects of "blow-by" common in reverse cycling. The pressure pedestals increase the sealing capability of the "D"-Ring, by reducing the radial pressure forces that compress the sealing face of the o-ring. The drawing below depicts the shape and highlights the features.

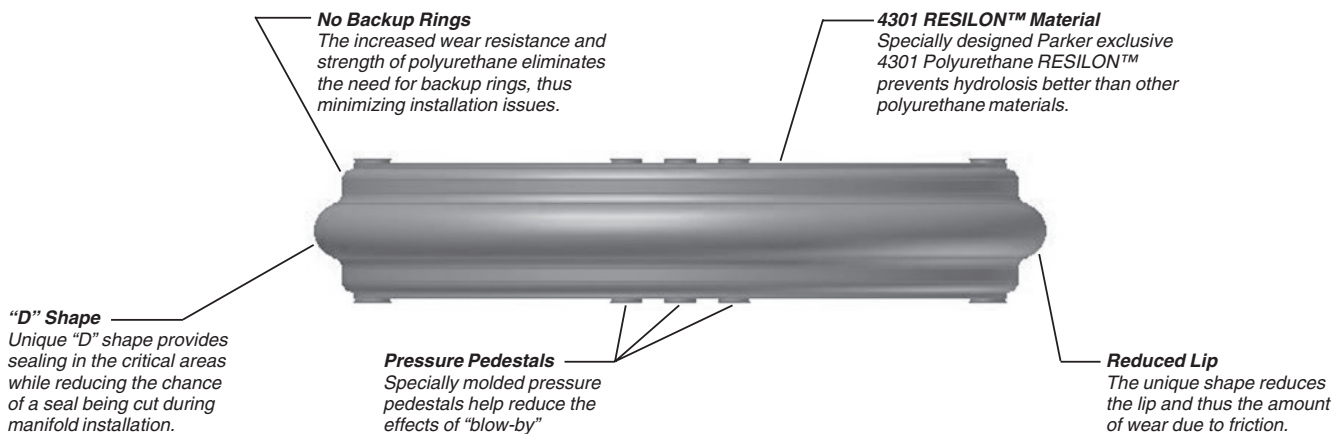

Nitrile

Nitrile o-rings are also compatible with most water-glycol, water/oil emulsions, and high grade petroleum based hydraulic fluids. Parker only recommends Nitrile o-rings for temperatures between -40°C to +93°C (-40°F to +200°F). Nitrile o-rings do require a full back-up ring, or two half back-ups.

Fluorocarbon

Fluorocarbon o-rings are compatible with most phosphate ester fluids and phosphate ester blends. Parker only recommends Fluorocarbon seals for temperatures between -32°C to +121°C (-25°F to +250°F). Fluorocarbon o-rings do require a full back-up ring, or two half back-ups.

CV
Check Valves

SH
Shuttle Valves

LM
Load/Motor Controls

FC
Flow Controls

PC
Pressure Controls

LE
Logic Elements

DC
Directional Controls

MV
Manual Valves

SV
Solenoid Valves

PV
Proportional Valves

CE
Coils & Electronics

BC
Bodies & Cavities

TD
Technical Data

CV	Check Valves
SH	Shuttle Valves
LM	Load/Motor Controls
FC	Flow Controls
PC	Pressure Controls
LE	Logic Elements
DC	Directional Controls
MV	Manual Valves
SV	Solenoid Valves
PV	Proportional Valves
CE	Cats & Electronics
BC	Bodies & Cavities
TD	Technical Data

HYDRAULIC FLUIDS

Parker recommends using top-quality mineral based or synthetic hydraulic fluids with lubricating properties at viscosities of 45 to 2000 SSU (6 to 420 cSt) at 38°C (100°F). The absolute viscosity range 80 to 1000 SSU (16 to 220 cSt.). Fluids should have high anti-wear characteristics and be treated to protect against oxidation.

HYDRAULIC FILTRATION

Hydraulic systems that include Parker valves should be carefully protected against fluid contamination. The proper cleanliness level for Parker cartridge valves should be maintained at an ISO cleanliness level of 18/16/13.

75% of all system failures are a direct result of contamination. Contamination interferes with four functions of hydraulic fluids.

1. To act as an energy transmission medium.
2. To lubricate internal moving parts of components.
3. To act a heat transfer medium.
4. To seal clearances between moving components.

A properly selected filter will provide adequate protection and reduce operating cost. This is achieved by increasing the expected life of the valves and reducing the cost of maintenance and repairs. Operation will be smoother and more precise.

There is no direct correlation between using a specific ISO cleanliness classification. Numerous other variables should be considered such as particulate ingestion, actual flow through filters, and filter location.

A number of interrelated system factors combine to determine proper media and filter combinations. To accurately determine which combination is ideal for your system, all these factors need to be accounted for. With the development of filtration sizing software such as Parker inPHorm, this information can be used to compute the optimal selection. In many instances the information available may be limited. In these cases, "rules of thumb" based on empirical data and proven examples are applied to get an initial starting point.

APPLICATION OF PRODUCT

CAUTION - It is important to note that the Parker Hydraulic Cartridge Systems Division makes a variety of valves, many of which fit into the same cavity. However, their functionality may differ considerably from one valve type to another. **Accordingly fit interchangeability does not necessarily mean form or function interchangeability.** Users should ensure that the appropriate valve is installed in the cavity by cross checking the part number stamped on the valve with that published in approved service literature or in the installation drawing.

Offer of Sale

The items described in this document and other documents or descriptions provided by Parker Hannifin Corporation, its subsidiaries and its authorized distributors are hereby offered for sale at prices to be established by Parker Hannifin Corporation, its subsidiaries and its authorized distributors. This offer and its acceptance by any customer ("Buyer") shall be governed by all of the following Terms and Conditions. Buyer's order for any such items, when communicated to Parker Hannifin Corporation, its subsidiary or an authorized distributor ("Seller") verbally or in writing, shall constitute acceptance of this offer.

1. Terms and Conditions of Sale: All descriptions, quotations, proposals, offers, acknowledgments, acceptances and sales of Seller's products are subject to and shall be governed exclusively by the terms and conditions stated herein. Buyer's acceptance of any offer to sell is limited to these terms and conditions. Any terms or conditions in addition to, or inconsistent with those stated herein, proposed by Buyer in any acceptance of an offer by Seller, are hereby objected to. No such additional, different or inconsistent terms and conditions shall become part of the contract between Buyer and Seller unless expressly accepted in writing by Seller. Seller's acceptance of any offer to purchase by Buyer is expressly conditional upon Buyer's assent to all the terms and conditions stated herein, including any terms in addition to, or inconsistent with those contained in Buyer's offer, Acceptance of Seller's products shall in all events constitute such assent.

2. Payment: Payment shall be made by Buyer net 30 days from the date of delivery of the items purchased hereunder. Amounts not timely paid shall bear interest at the maximum rate permitted by law for each month or portion thereof that the Buyer is late in making payment. Any claims by Buyer for omissions or shortages in a shipment shall be waived unless Seller receives notice thereof within 30 days after Buyer's receipt of the shipment.

3. Delivery: Unless otherwise provided on the face hereof, delivery shall be made F.O.B. Seller's plant. Regardless of the method of delivery, however, risk of loss shall pass to Buyer upon Seller's delivery to a carrier. Any delivery dates shown are approximate only and Seller shall have no liability for any delays in delivery.

4. Warranty: Seller warrants that the items sold hereunder shall be free from defects in material or workmanship for a period of 18 months from date of shipment from Parker Hannifin Corporation. **THIS WARRANTY COMPRISES THE SOLE AND ENTIRE WARRANTY PERTAINING TO ITEMS PROVIDED HEREUNDER. SELLER MAKES NO OTHER WARRANTY, GUARANTEE, OR REPRESENTATION OF ANY KIND WHATSOEVER. ALL OTHER WARRANTIES, INCLUDING BUT NOT LIMITED TO, MERCHANTABILITY AND FITNESS FOR PURPOSE, WHETHER EXPRESS, IMPLIED, OR ARISING BY OPERATION OF LAW, TRADE USAGE, OR COURSE OF DEALING ARE HEREBY DISCLAIMED. NOTWITHSTANDING THE FOREGOING, THERE ARE NO WARRANTIES WHATSOEVER ON ITEMS BUILT OR ACQUIRED WHOLLY OR PARTIALLY, TO BUYER'S DESIGNS OR SPECIFICATIONS.**

5. Limitation Of Remedy: SELLER'S LIABILITY ARISING FROM OR IN ANY WAY CONNECTED WITH THE ITEMS SOLD OR THIS CONTRACT SHALL BE LIMITED EXCLUSIVELY TO REPAIR OR REPLACEMENT OF THE ITEMS SOLD OR REFUND OF THE PURCHASE PRICE PAID BY BUYER, AT SELLER'S SOLE OPTION. IN NO EVENT SHALL SELLER BE LIABLE FOR ANY INCIDENTAL, CONSEQUENTIAL OR SPECIAL DAMAGES OF ANY KIND OR NATURE WHATSOEVER, INCLUDING BUT NOT LIMITED TO LOST PROFITS ARISING FROM OR IN ANY WAY CONNECTED WITH THIS AGREEMENT OR ITEMS SOLD HEREUNDER, WHETHER ALLEGED TO ARISE FROM BREACH OF CONTRACT, EXPRESS OR IMPLIED WARRANTY, OR IN TORT, INCLUDING WITHOUT LIMITATION, NEGLIGENCE, FAILURE TO WARN OR STRICT LIABILITY.

6. Changes, Reschedules and Cancellations: Buyer may request to modify the designs or specifications for the items sold hereunder as well as the quantities and delivery dates thereof, or may request to cancel all or part of this order, however, no such requested modification or cancellation shall become part of the contract between Buyer and Seller unless accepted by Seller in a written amendment to this Agreement. Acceptance of any such requested modification or cancellation shall be at Seller's discretion, and shall be upon such terms and conditions as Seller may require.

7. Special Tooling: A tooling charge may be imposed for any special tooling, including without limitation, dies, fixtures, molds and patterns, acquired to manufacture items sold pursuant to this contract. Such special tooling shall be and remain Seller's property notwithstanding payment of any charges by Buyer. In no event will Buyer acquire any interest in apparatus belonging to Seller which is utilized in the manufacture of the items sold hereunder, even if such apparatus has been specially converted or adapted for such manufacture and notwithstanding any charges paid

by Buyer. Unless otherwise agreed, Seller shall have the right to alter, discard or otherwise dispose of any special tooling or other property in its sole discretion at any time.

8. Buyer's Property: Any designs, tools, patterns, materials, drawings, confidential information or equipment furnished by Buyer or any other items which become Buyer's property, may be considered obsolete and may be destroyed by Seller after two (2) consecutive years have elapsed without Buyer placing an order for the items which are manufactured using such property, Seller shall not be responsible for any loss or damage to such property while it is in Seller's possession or control.

9. Taxes: Unless otherwise indicated on the face hereof, all prices and charges are exclusive of excise, sales, use, property, occupational or like taxes which may be imposed by any taxing authority upon the manufacture, sale or delivery of the items sold hereunder. If any such taxes must be paid by Seller or if Seller is liable for the collection of such tax, the amount thereof shall be in addition to the amounts for the items sold. Buyer agrees to pay all such taxes or to reimburse Seller therefore upon receipt of its invoice. If Buyer claims exemption from any sales, use or other tax imposed by any taxing authority, Buyer shall save Seller harmless from and against any such tax, together with any interest or penalties thereon which may be assessed if the items are held to be taxable.

10. Indemnity For Infringement of Intellectual Property Rights: Seller shall have no liability for infringement of any patents, trademarks, copyrights, trade dress, trade secrets or similar rights except as provided in this Part 10. Seller will defend and indemnify Buyer against allegations of infringement of U.S. Patents, U.S. Trademarks, copyrights, trade dress and trade secrets (hereinafter 'Intellectual Property Rights'). Seller will defend at its expense and will pay the cost of any settlement or damages awarded in an action brought against Buyer based on an allegation that an item sold pursuant to this contract infringes the Intellectual Property Rights of a third party. Seller's obligation to defend and indemnify Buyer is contingent on Buyer notifying Seller within ten (10) days after Buyer becomes aware of such allegations of infringement, and Seller having sole control over the defense of any allegations or actions including all negotiations for settlement or compromise. If an item sold hereunder is subject to a claim that it infringes the Intellectual Property Rights of a third party, Seller may, at its sole expense and option, procure for Buyer the right to continue using said item, replace or modify said item so as to make it noninfringing, or offer to accept return of said item and return the purchase price less a reasonable allowance for depreciation. Notwithstanding the foregoing, Seller shall have no liability for claims of infringement based on information provided by Buyer, or directed to items delivered hereunder for which the designs are specified in whole or part by Buyer, or infringements resulting from the modification, combination or use in a system of any item sold hereunder. The foregoing provisions of this Part 10 shall constitute Seller's sole and exclusive liability and Buyer's sole and exclusive remedy for infringement of Intellectual Property Rights. If a claim is based on information provided by Buyer or if the design for an item delivered hereunder is specified in whole or in part by Buyer, Buyer shall defend and indemnify Seller for all costs, expenses or judgments resulting from any claim that such item infringes any patent, trademark, copyright, trade dress, trade secret or any similar right.

11. Force Majeure: Seller does not assume the risk of and shall not be liable for delay or failure to perform any of Seller's obligations by reason of circumstances beyond the reasonable control of Seller (hereinafter 'Events of Force Majeure'). Events of Force Majeure shall include without limitation, accidents, acts of God, strikes or labor disputes, acts, laws, rules or regulations of any government or government agency, fires, floods, delays or failures in delivery of carriers or suppliers, shortages of materials and any other cause beyond Seller's control.

12. Entire Agreement/Governing Law: The terms and conditions set forth herein, together with any amendments, modifications and any different terms or conditions expressly accepted by Seller in writing, shall constitute the entire Agreement concerning the items sold, and there are no oral or other representations or agreements which pertain thereto. This Agreement shall be governed in all respects by the law of the State of Ohio. No actions arising out of the sale of the items sold hereunder or this Agreement may be brought by either party more than two (2) years after the cause of action accrues.

CV

Check Valves

SH

Shuttle Valves

LM

Load/Motor Controls

FC

Flow Controls

PC

Pressure Controls

LE

Logic Elements

DC

Directional Controls

MV

Manual Valves

SV

Solenoid Valves

PV

Proportional Valves

CE

Coils & Electronics

BC

Bodies & Cavities

TD

Technical Data



