

SERIES	CAVITY	DESCRIPTION	FLOW LPM/GPM	PRESSURE BAR/PSI	PAGE NO.
STANDARD PILOT ASSISTED					
	CB101	C10-3 Load Control Cartridge Valve	45/12	380/5500	LM5-LM6
	MHC-010-S***	CDD-1010 ... Load Control Cartridge Valve	37/10	350/5000	LM7-LM8
	MHC-022-S***	CDD-1036 ... Load Control Cartridge Valve	94/25	350/5000	LM9-LM10
	E2*020	53-1 Load Control Cartridge Valve	20/5.3	420/6000	LM11-LM12
	E2*040	68-1 Load Control Cartridge Valve	60/16	350/5000	LM13-LM14
	E2*1	T11-A Load Control Cartridge Valve	60/16	350/5000	LM15-LM16
	E2*1S	T11-A Load Control Cartridge Valve	60/16	350/5000	LM17-LM18
	E2*1R	T11-A Load Control Cartridge Valve	60/16	350/5000	LM19-LM20
	E2*060	3C Load Control Cartridge Valve	120/32	350/5000	LM21-LM22
	E2*125	3M Load Control Cartridge Valve	200/53	350/5000	LM23-LM24
E2*300	3K Flange	350/90	350/5000	LM25-LM26	
INDEPENDENT OF BACK-PRESSURE, VENTED TO ATMOSPHERE					
	E6B020	53-1 Load Control Cartridge Valve, 4.5:1 Ratio	20/5.3	350/5000	LM27-LM28
	E6K020	53-1 Load Control Cartridge Valve, 15:1 Ratio	20/5.3	350/5000	LM29-LM30
	E6*1	T11-A Load Control Cartridge Valve	60/16	350/5000	LM31-LM32
	E6B040	3C Load Control Cartridge Valve, 3:1 Ratio	60/16	350/5000	LM33-LM34
	E6A060*409	3C Load Control Cartridge Valve, 3:1 Ratio	180/48	350/5000	LM35-LM36
	E6B060*409	3C Load Control Cartridge Valve, 3:1 Ratio	180/48	350/5000	LM35-LM36
	MHC-010-V***	CDD-1010 ... Load Control Cartridge Valve	37/10	350/5000	LM7-LM8
	MHC-022-V***	CDD-1036 ... Load Control Cartridge Valve	94/25	350/5000	LM9-LM10
INDEPENDENT OF BACK-PRESSURE, VENTED TO DRAIN ON PORT 4					
	E9*1	T21A Load Control Cartridge Valve	60/16	350/5000	LM37-LM38

- CV**
Check Valves
- SH**
Shuttle Valves
- LM**
Load/Motor Controls
- FC**
Flow Controls
- PC**
Pressure Controls
- LE**
Logic Elements
- DC**
Directional Controls
- MV**
Manual Valves
- SV**
Solenoid Valves
- PV**
Proportional Valves
- CE**
Coils & Electronics
- BC**
Bodies & Cavities
- TD**
Technical Data

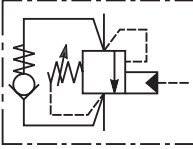
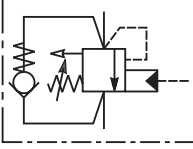
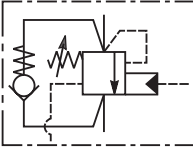

- CV** Check Valves
- SH** Shuttle Valves
- LM** Load/Motor Controls
- FC** Flow Controls
- PC** Pressure Controls
- LE** Logic Elements
- DC** Directional Controls
- MV** Manual Valves
- SV** Solenoid Valves
- PV** Proportional Valves
- CE** Cols & Electronics
- BC** Bodies & Cavities
- TD** Technical Data

Introduction

Counterbalance valves are one of the most misunderstood products in the hydraulic industry. Many people tend to complicate the task of selecting a counterbalance valve and as such avoid opportunities. The goal of this Technical Tips Section is to hopefully eliminate some of this confusion and help you chose the correct valve for your application. It is only a guide! It is not meant to be your only method of input, nor is it meant to replace good hydraulic common sense and reasoning.

Application

DO I NEED A COUNTERBALANCE VALVE?

A counterbalance is generally used for one or more of the following purposes:

Control an Overrunning Load – It restricts the flow from an actuator, thus forcing the load to be pushed through the restriction and providing control of the potential runaway load. This also helps in the prevention of cavitation.

Control in Critical Metering Applications – The outward restriction also helps to gain control of systems with varying loads and speeds.

Holding a Load – Much like a pilot operated check valve, a load is held in one direction until the appropriate pilot pressure is available unseat the check and pass fluid.

Help Protect Against Hose Failures – Since the fluid must be pushed through a restriction, hose failures result in a controlled movement of the actuator and not a runaway load.

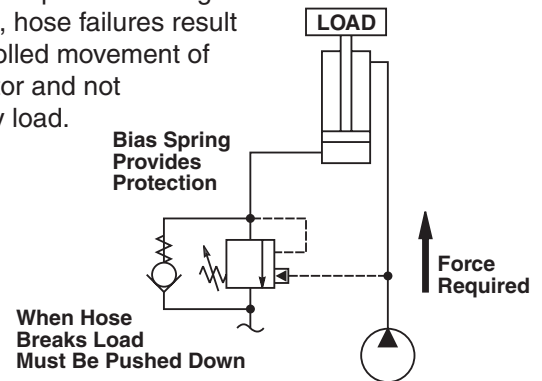

NOTE: Counterbalance Valves are only needed if the application calls for varying loads or varying speeds. If the load and speed are fixed, flow control valves and pilot operated check valves may be substituted at generally a lower cost.

Operation

An understanding of the general operation of a counterbalance valve is required before proceeding further into valve selection.

The counterbalance valve is a pressure control device and functions as follows: Pressure is developed at the Work Port of the holding valve when the actuator is pressurized. This pressure acts on the differential area, and the force generated is counteracted by the bias spring. When there is sufficient pressure present to overcome the spring setting, the poppet begins to shift, allowing fluid to pass through the valve port to tank via the control valve.

To assist in the shifting of the poppet, an external pressure source (generally the opposite side of the actuator) is connected to the pilot port of the counterbalance valve. This pressure is applied to the pilot area and assists the differential area in opening the valve. The pilot assist reduces load pressure required to open the valve, and allows for a reduction in the horsepower required to move the load. If the load attempts to “run away” (move faster than the pump can supply flow), the pilot signal will diminish and the piston will begin to close restricting flow to tank and thus controlling the load. The counterbalance piston will maintain a position that maintains a positive pilot signal and will control the descent of the load.

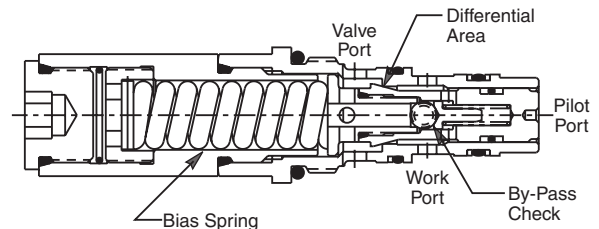

An added feature of the counterbalance valve is its built-in thermal relief characteristic. A temperature rise can cause thermal expansion of the hydraulic fluid trapped between the actuator and the counterbalance valve’s poppet. As the pressure increases and reaches the bias spring setting, the poppet unseats and a few drops of oil are allowed to escape through the valve port of the counterbalance valve. This relieves the thermal expansion of oil, allowing the counterbalance valve to continue holding the load in the same position. When the flow is reversed to the actuator, then pressure unseats the built-in bypass check portion of the counterbalance valve allowing flow to pass from the valve port to the work port. When no pressure is applied to either port of the counterbalance valve, the load is held in place.

Valve Series

Parker offers the four series of products outlined below:

MHC – The MHC series is a threaded cartridge style counterbalance valve. This series is ideal for incorporating into an integrated manifold or for installation directly into the port of the actuator. There are various flow rates and pilot ratios available for the MHC Series.

CB101 – The CB101 is also a threaded cartridge style counterbalance valve. It also is ideal for incorporating into an integrated manifold or for installation directly into the port of the actuator. The CB101 has an industry common cavity (C10-3) and is available in three pilot ratios.

E2 Series – The E2 Series valves are threaded cartridge style counterbalance valves. They are available in standard and Vented configurations. In the Vented configurations, the valves maintain their settings regardless of system backpressure. There are various flow rates and pilot ratios available.



Selecting Options

Below is a brief description of the options available on the ordering information pages and a brief explanation of when each would be used.

Flow Selection – Generally the counterbalance valve is sized according to the actual flow the valve will see and not the system flow. Note that the ordering information callout is the nominal flow rate and not the maximum. In other words, refer to the pressure drop curves when sizing the valves. For example: A MHC-010 can flow 25 GPM, but is rated as a 10 GPM valve. It is possible to oversize a counterbalance valve! If the counterbalance is oversized, the annulus between the poppet and the seat is too large, thus the poppet opens too far causing instability. Remember you are gaining control by causing a restriction. If you oversize the counterbalance valve, the restriction is reduced and so is the control.

Vented versus Non-Vented – With a standard counterbalance valve, the bias spring is internally vented to tank. This means any pressure on the tank line is sensed in the bias spring chamber and additive to the setting. Thus, the pressure at the work port now must

be greater than the bias spring plus the tank pressure before the counterbalance poppet will shift allowing flow.

A vented style counterbalance valve relieves the bias spring chamber to atmosphere. Thus, the spring chamber is in no way related to the tank chamber of the counterbalance valve. So, if the pressure on the tank line is high, or if the pressure setting is critical, then a vented style counterbalance valve would be required.

Parker's counterbalance valves are externally vented. This means no extra porting or manifold costs are incurred when a vented counterbalance is needed.

MHC-010-S*S* Non-Vented Counterbalance Adjustable

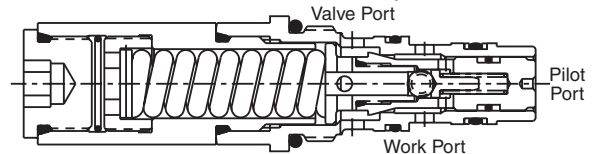

MHC-010-V*S* Vented Counterbalance Adjustable

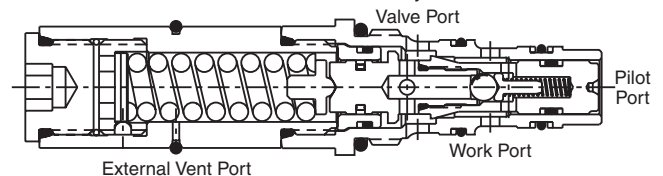

CV

Check Valves

SH

Shuttle Valves

LM

Load/Motor Controls

FC

Flow Controls

PC

Pressure Controls

LE

Logic Elements

DC

Directional Controls

MV

Manual Valves

SV

Solenoid Valves

PV

Proportional Valves

CE

Coils & Electronics

BC

Bodies & Cavities

TD

Technical Data

- CV Check Valves
- SH Shuttle Valves
- LM Load/Motor Controls
- FC Flow Controls
- PC Pressure Controls
- LE Logic Elements
- DC Directional Controls
- MV Manual Valves
- SV Solenoid Valves
- PV Proportional Valves
- CE Coils & Electronics
- BC Bodies & Cavities
- TD Technical Data

Selection Options (Continued)

Pilot Ratio – The pilot ratio is the ratio of the pilot area versus the differential area poppet. Thus, the higher the pilot ratio, the less pressure that is needed to assist the load pressure in unseating the poppet. This means there is less restriction to the overrunning load, resulting in less horsepower required and more control of the load. So higher pilot ratio equates to less restriction to the overrunning load, less control and less horsepower required. Lower ratio equates to more restriction to the overrunning load, more control and more horsepower required.

The pilot ratio decision is one of Horsepower versus Control. For reference the most popular ratio is 6:1.

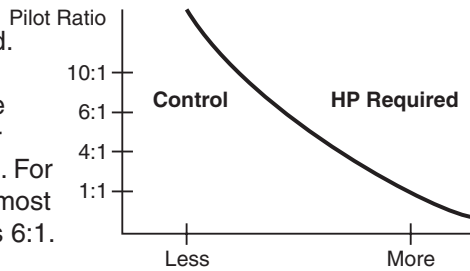

Sample Ratios:

10:1

Primary function is load holding or hose break protection
Loads moving at fast speeds and positioning is not critical

7:1, 6:1 and 5:1

Most popular starting ratio

4:1 and 3:1

Positioning is critical such as a pick and place application
Instability with 6:1 ratio

1:1

Motor control application

ADJUSTMENT TYPE

Parker offers counterbalance valves with adjustable and non-adjustable pressure settings. The non-adjustable or shimmed version is recommended for most applications as it prevents tampering or improper adjustment by uneducated end users.

SELECTING SETTINGS

There are three basic settings to consider before finalizing a counterbalance valve for your application.

Holding Setting – The holding setting is sometimes referred to as the counterbalance setting. It is the maximum load setting you expect the counterbalance to hold. Note that the counterbalance valve should be set for the absolute maximum hold pressure required. Also note that counterbalance valves are restrictive type devices and as such are not ideal for low pressure applications, such as those below 750 psi. The holding setting is the setting you choose when selecting a counterbalance valve.

Thermal Setting – Counterbalance valves have a built-in thermal relief valve that compensates for the expansion of oil, due to temperature, by bleeding off excess pressure. In other words, the thermal setting is the pressure that the counterbalance will unload at if no pressure is present at the pilot port. Obviously, this setting should be above the holding setting. The Parker **MHC** counterbalance valves are automatically set 1000 psi above the holding setting of the valve. **You do not specify this setting, only the holding setting.** For the **CB101** Series, you do specify the Thermal/Crack setting in the model code. The holding setting (maximum load induced pressure) is 70% of that specified setting. Example: Hold at 3000 psi, crack at 4285 psi. For the **E2** Series, you specify the Thermal/Crack setting in the model code. The crack setting (maximum load induced pressure) should be 1.3 times the hold. Example: Hold at 3000 psi, crack at 3900 psi.

Pilot Area – The pilot pressure required to lower the cylinder when fully loaded and unloaded can also be determined before applying the valve. The pilot pressure can be determined by the below equation:

$$P_p = (T_s - L) / R_p$$

P_p = Pilot Pressure

T_s = Thermal Setting

L = Induced Load

R_p = Pilot Ratio

Example:

The maximum load is 3000 psi. A 6:1 Pilot Ratio was chosen and the thermal relief setting is the standard 1000 psi over load setting. What is the pilot pressure required to retract the cylinder if it is fully loaded? What pilot pressure is required to retract the cylinder if there is no load?

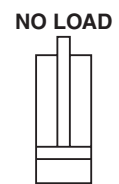
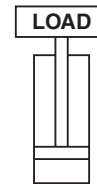

FULLY LOADED:

$$P_p = (4000 \text{ psi} - 3000 \text{ psi}) / 6$$

$$P_p = 1000 \text{ psi} / 6$$

$$P_p = 167 \text{ psi}$$

Thus, any time the pilot line sees at least 167 psi, the cylinder could lower the load.

UNLOADED:

$$P_p = (4000 \text{ psi} - 0 \text{ psi}) / 6$$

$$P_p = 4000 \text{ psi} / 6$$

$$P_p = 667 \text{ psi}$$

Thus, at least 667 psi will be needed to lower the cylinder when it is unloaded.

Motor Controls

Counterbalance valves are used in motor circuits to stop overrunning loads and prevent cavitation. Since hydraulic motors leak internally, the counterbalance valve by itself cannot be used to hold the load. So, a mechanical brake is used to hold the load on the motor in place, as shown below. Some typical applications include winches, swing drives, conveyor control and traction drives. For applications in closed loop motor circuits, vented spring cavities are required.

Operation

Free flow to the motor is allowed through the internal check valve. In the controlled flow direction, the oil passes across a metering poppet. The position of the metering poppet is determined by an external pilot signal from the other side of the motor. In an open loop motor circuit, this pilot signal will be a 1:1 ratio. The reason an equal ratio pilot signal is utilized is to provide positive control as well as to release mechanical brakes (when used in a braking circuit). In applications where the motor will see overrunning loads in both directions (such as a traction drive circuit), a dual MMB or two single MMB valves must be used.

Brake Applications

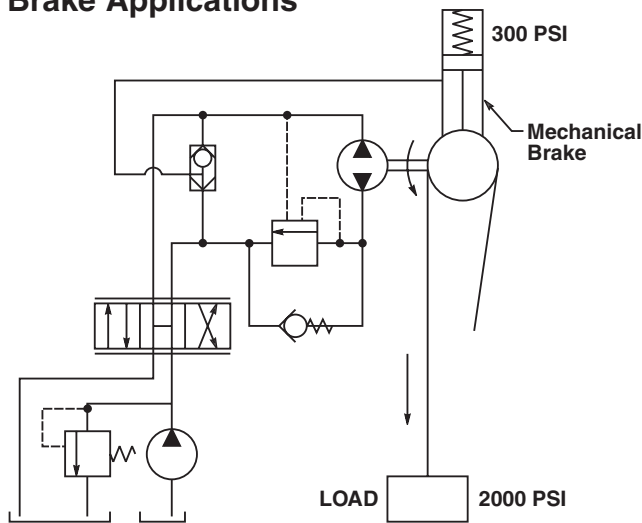

When the directional control valve is shifted, hydraulic pressure (usually 300 psi) releases the mechanical brake and allows the load to be moved. The counterbalance valve needs to provide adequate back pressure to open the brake, then immediately counterbalance the load. Ideally, the brake will be disengaged before the motor begins to rotate. If this sequence is not achieved, the motor will try to rotate against the applied brake reducing the life of the brake. This would be the equivalent of trying to drive with your emergency brake applied. Remember that hydraulic motors are equal area devices. So, in an effort to avoid the

movement of the motor prior to the release of the brake, an equal area ratio counterbalance is used. To demonstrate let's look again at the above example with a 10:1 Ratio Counterbalance valve installed and a maximum thermal setting of 3000 psi.

10:1 Example

NO LOAD

$$P_p = (T_s - L) / R_p$$

$$P_p = (3000 \text{ psi} - 0 \text{ psi}) / 10$$

$$P_p = 3000 \text{ psi} / 10$$

$$P_p = 300 \text{ psi}$$

2000 PSI LOAD

$$P_p = (T_s - L) / R_p$$

$$P_p = (3000 \text{ psi} - 2000 \text{ psi}) / 10$$

$$P_p = 1000 \text{ psi} / 10$$

$$P_p = 100 \text{ psi}$$

Thus, when there is no load on the motor, the counterbalance opens at 300 psi, or just as the brake is being released. When there is a 2000 psi load on the motor, the counterbalance will start to open with a pilot pressure of 100 psi. The brake requires 300 psi, so the motor can start to rotate before the brake is released, causing wear on the brake. To offset this problem, you could increase the maximum thermal setting to 5000 psi, but this is very inefficient.

1:1 (Equal Area) Example

Equal area counterbalance valves are used primarily in brake applications to avoid the wear problem described above. With an Equal Area counterbalance valve, there is no thermal relief valve, and there is no differential area to work on. In other words, the counterbalance valve only opens when the pilot pressure is greater than the valve setting. The applied load has nothing to do with the pilot pressure required. Thus you will want to choose a pressure setting for the equal area counterbalance valve that is just slightly above the brake release pressure (usually 350 psi).

In our example, the valve would be set at 350 psi. This would allow the brake to release before the counterbalance allows the load to move. Since the equal counterbalance valve always opens at 350 psi pilot pressure and is not dependent on the load, it is the best valve for brake applications.

Large Pressure Spike Application – Keep in mind that equal area counterbalance valves do not have a built-in thermal relief valve. As such, if there are large pressure spikes caused by the stopping of heavy loads, then a ratioed counterbalance, such as a 10:1 should be used. In most cases these are non-brake type applications.

CV

Check Valves

SH

Shuttle Valves

LM

Load/Motor Controls

FC

Flow Controls

PC

Pressure Controls

LE

Logic Elements

DC

Directional Controls

MV

Manual Valves

SV

Solenoid Valves

PV

Proportional Valves

CE

Coils & Electronics

BC

Bodies & Cavities

TD

Technical Data

Technical Information

- CV** Check Valves
- SH** Shuttle Valves
- LM** Load/Motor Controls
- FC** Flow Controls
- PC** Pressure Controls
- LE** Logic Elements
- DC** Directional Controls
- MV** Manual Valves
- SV** Solenoid Valves
- PV** Proportional Valves
- CE** Coils & Electronics
- BC** Bodies & Cavities
- TD** Technical Data

General Description

Cartridge Style Counterbalance Valve.
For additional information see Technical Tips on pages LM1-LM4.

Features

- Sealed spool type design for improved stability and accuracy as well as low leakage
- Low leakage poppet-type check valve for reliable load holding
- All external parts have yellow zinc dichromate finish.
- Parker cartridge design for ease of installation and maintenance
- Compact size for reduced space requirements

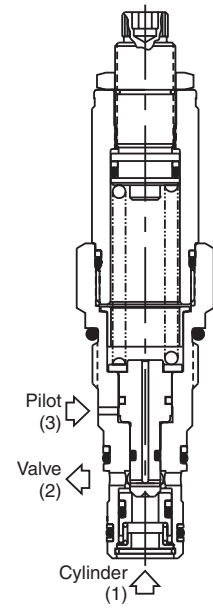
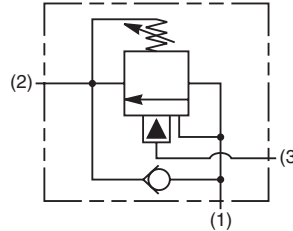
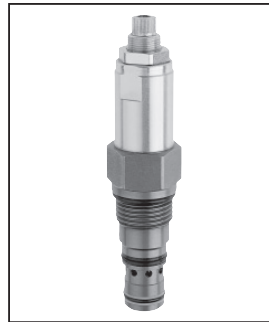

Specifications

Rated Flow	45 LPM (12 GPM)
Maximum Inlet Pressure	380 Bar (5500 PSI) - Steel 210 Bar (3000 PSI) - Aluminum
Maximum Setting Pressure	350 Bar (5000 PSI) - Steel 210 Bar (3000 PSI) - Aluminum
Leakage at 150 SSU (32 cSt)	5 drops/min. (.33 cc/min.) @ 80% of thermal crack pressure
Cartridge Material	All parts steel. All operating parts hardened steel.
Operating Temp. Range/Seals	-40°C to +93.3°C (Nitrile) (-40°F to +200°F) -31.7°C to +121.1°C (Fluorocarbon) (-25°F to +250°F)
Fluid Compatibility/Viscosity	Mineral-based or synthetic with lubricating properties at viscosities of 45 to 2000 SSU (6 to 420 cSt)
Filtration	ISO Code 16/13, SAE Class 4 or better
Approx. Weight	.23 kg (0.5 lbs.)
Cavity	C10-3 (See BC Section for more details)
Form Tool	Rougher NFT10-3R Finisher NFT10-3F

Performance Curve
Flow vs. Pressure Drop
(Through cartridge only)

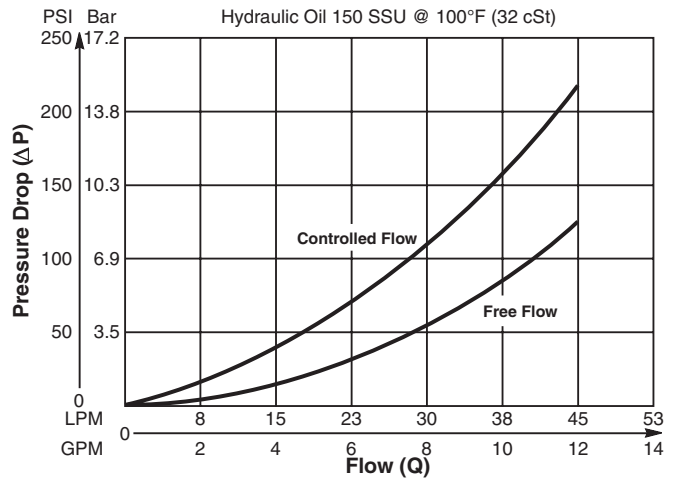

Dimensions Millimeters (Inches)

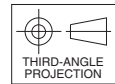
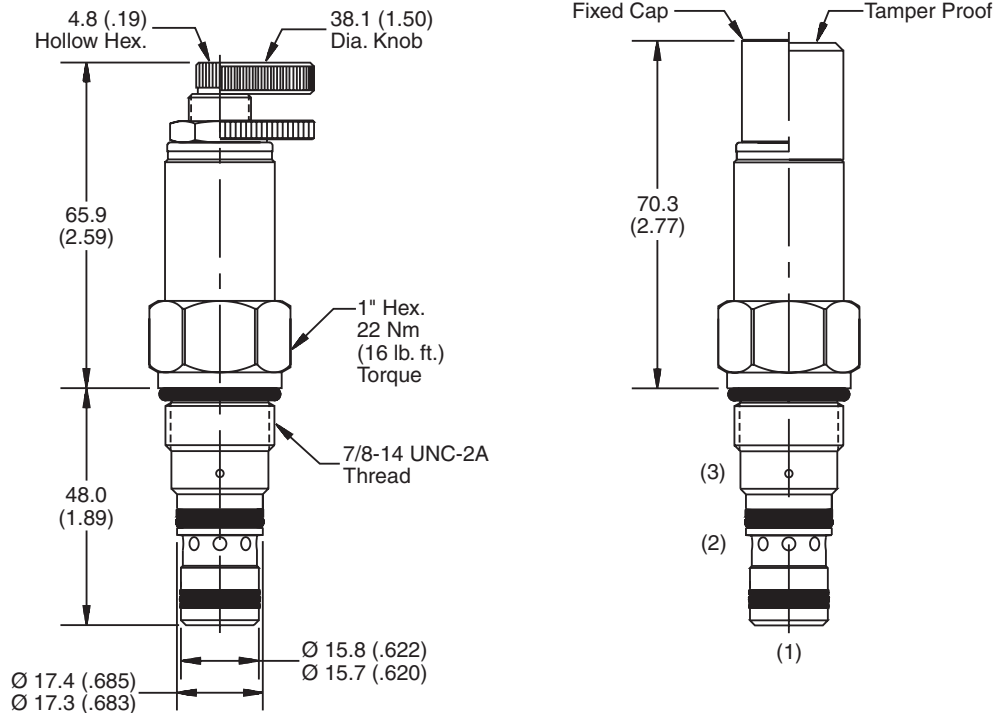

Ordering Information

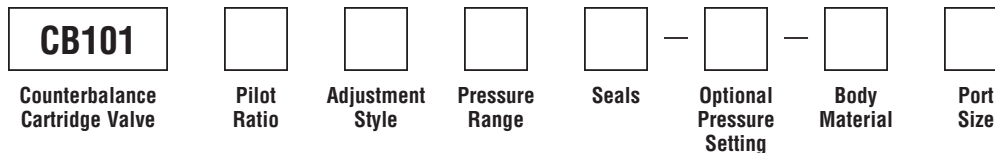

Code	Pilot Ratio
A	3:1
B	4.5:1
C	7:1

Code	Pressure Range
10	20.7 - 90 Bar (300 - 1300 PSI) Standard Setting: 69 Bar (1000 PSI) @ 11.3 LPM (3 GPM)
20	69 - 172.4 Bar (1000 - 2500 PSI) Standard Setting: 138 Bar (2000 PSI) @ 11.3 LPM (3 GPM)
30	138 - 350 Bar (2000 - 5000 PSI) Standard Setting: 210 Bar (3000 PSI) @ 11.3 LPM (3 GPM)

Code	Seals / Kit No.
Omit	Nitrile / (SK10-3N)
V	Fluorocarbon / (SK10-3V)

Code	Body Material
Omit	Steel
A	Aluminum

Code	Adjustment Style/Kit No.
F	Fixed style, preset at factory.
K	Knob Adjust (717784-10)
S	Screw Adjust
T	Tamper Resistant Cap (717785)

Optional Pressure Setting
Pressure \pm 10 i.e. 235 = 2350 PSI Setting Range: 300 to 5000 PSI All settings at 11.3 LPM (3 GPM)

Code	Port Size	Body Part No.
Omit	Cartridge Only	
6T	SAE-6	(B10-3-*6T)
8T	SAE-8	(B10-3-*8T)
6B	3/8" BSPG	(B10-3-6B)†
8B	1/2" BSPG	(B10-3-*8B)

* Body is available in steel or aluminum.
 † Steel body only.

Technical Information

- CV** Check Valves
- SH** Shuttle Valves
- LM** Load/Motor Controls
- FC** Flow Controls
- PC** Pressure Controls
- LE** Logic Elements
- DC** Directional Controls
- MV** Manual Valves
- SV** Solenoid Valves
- PV** Proportional Valves
- CE** Coils & Electronics
- BC** Bodies & Cavities
- TD** Technical Data

General Description

Threaded Cartridge Style Counterbalance Valve. For additional information see Technical Tips on pages LM1-LM4.

Features

- Conical Poppet design provides longer metering stroke for stable operation
- Hardened seat provides reliable load holding
- External vent option available for high back pressure applications
- Tamper resistant cap for added safety and security
- Various pilot ratios available for application flexibility
- Unique cavity prevents other valves from being “accidentally” installed
- All external parts zinc plated

Specifications

Rated Flow	37.5 LPM (10 GPM)
Maximum Inlet Pressure	350 Bar (5000 PSI)
Leakage at 150 SSU (32 cSt)	5 drops/min. (.33 cc/min.) @ 80% of thermal crack pressure
Cartridge Material	All parts steel. All operating parts hardened steel.
Operating Temp. Range/Seals	-40°C to +93.3°C (Nitrile) (-40°F to +200°F) -31.7°C to +121.1°C (Fluorocarbon) (-25°F to +250°F)
Fluid Compatibility/Viscosity	Mineral-based or synthetic with lubricating properties at viscosities of 45 to 2000 SSU (6 to 420 cSt)
Filtration	ISO Code 16/13, SAE Class 4 or better
Approx. Weight	.38 kg (.88 lbs.)
Cavity	CDD-1010 (See BC Section for more details)
Form Tool	FR-500

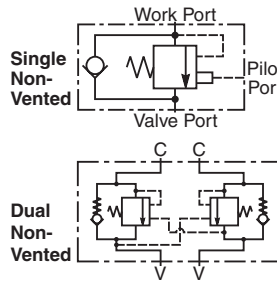
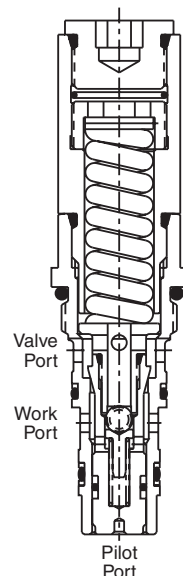
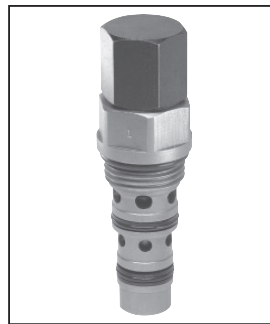

MHC-010-S*S* Non-Vented Counterbalance Adjustable

Construction

MHC-010-V*S* Vented Counterbalance Adjustable

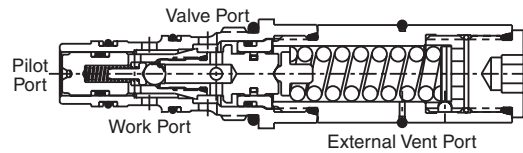

MHC-010-S*N* Non-Vented Counterbalance Non-Adjustable

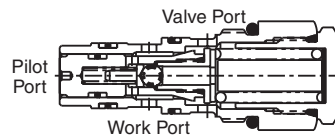

MHC-010-V*N* Vented Counterbalance Non-Adjustable

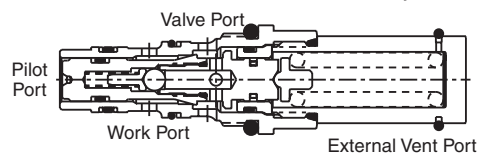

Performance Curve

Flow vs. Pressure Drop (Through cartridge only)

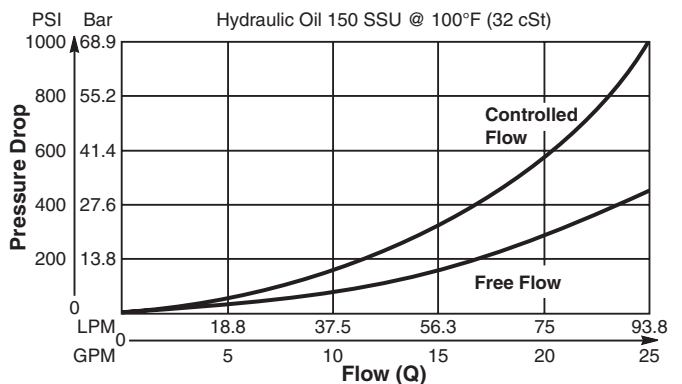

Dimensions Millimeters (Inches)

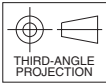
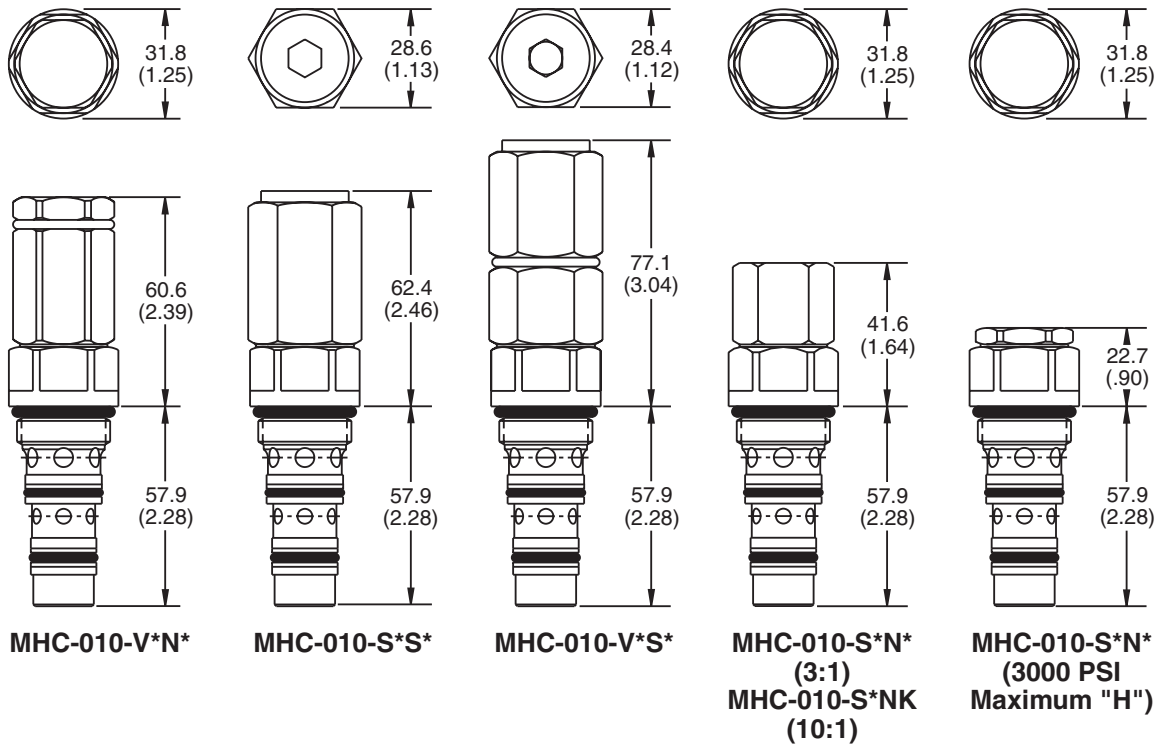

Torque Values
 68-75 Nm (50-55 lb. ft.)
Typical for all

Ordering Information

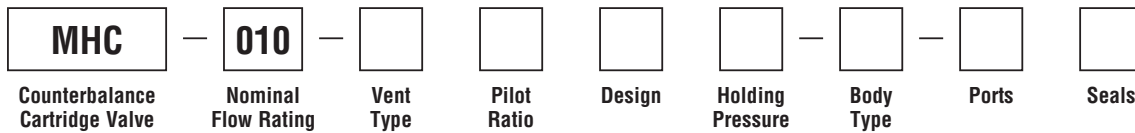

Code	Nominal Flow Rating
010	37.5 LPM (10 GPM)

Code	Vent Type
S	Standard (non-vented)
V	Vented

Code	Pilot Ratio
A	Equal Area (1:1)
B	4:1
F	7:1 (Standard)
J	10:1

Code	Design
S	Standard (adjustable)
N	Shimmed (non-adjustable)

Code	Holding Pressure
C	Equal Area 34.5 Bar (500 PSI) Crack
D	69 Bar (1000 PSI) Shim adjustable version only
E	105 Bar (1500 PSI)
F	140 Bar (2000 PSI)
G	170 Bar (2500 PSI)
H	210 Bar (3000 PSI) Standard version
K	350 Bar (5000 PSI) 7:1 and 10:1 only Shim version only

Code	Body Type	Part Number
Omit	No Body	
A	Single	MHC-010-A-53
D	Dual	MHC-010-D-53

Code	Ports
00	No Ports
52	SAE-8 through port
53	SAE-10 through port

Code	Seals / Kits
B	Nitrile / 711922
F	Fluorocarbon / 711825

Technical Information

- CV** Check Valves
- SH** Shuttle Valves
- LM** Load/Motor Controls
- FC** Flow Controls
- PC** Pressure Controls
- LE** Logic Elements
- DC** Directional Controls
- MV** Manual Valves
- SV** Solenoid Valves
- PV** Proportional Valves
- CE** Coils & Electronics
- BC** Bodies & Cavities
- TD** Technical Data

General Description

Threaded Cartridge Style Counterbalance Valve. For additional information see Technical Tips on pages LM1-LM5.

Features

- Conical Poppet design provides longer metering stroke for stable operation
- Hardened seat provides reliable load holding
- External vent option available for high back pressure applications
- Tamper resistant cap for added safety and security
- Various pilot ratios available for application flexibility
- Unique cavity prevents other valves from being “accidentally” installed
- All external parts zinc plated

Specifications

Rated Flow	93.75 LPM (25 GPM)
Maximum Inlet Pressure	350 Bar (5000 PSI)
Leakage at 150 SSU (32 cSt)	5 drops/min. (.33 cc/min.) @ 80% of thermal crack pressure
Cartridge Material	All parts steel. All operating parts hardened steel.
Operating Temp. Range/Seals	-40°C to +93.3°C (Nitrile) (-40°F to +200°F) -31.7°C to +121.1°C (Fluorocarbon) (-25°F to +250°F)
Fluid Compatibility/ Viscosity	Mineral-based or synthetic with lubricating properties at viscosities of 45 to 2000 SSU (6 to 420 cSt)
Filtration	ISO Code 16/13, SAE Class 4 or better
Approx. Weight	.44 kg (1.0 lbs.)
Cavity	CDD-1036 (See BC Section for more details)
Form Tool	FR-501

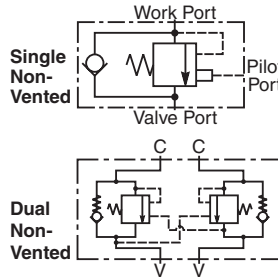
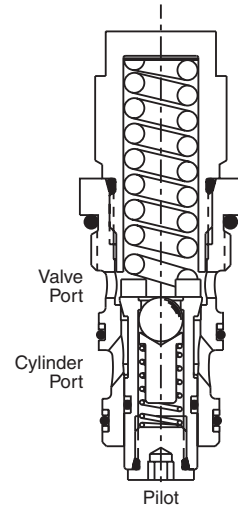
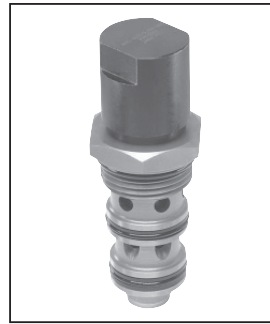

MHC-022-S*N*
Non-Vented Counterbalance
Non-Adjustable

Construction

MHC-022-S*S* Non-Vented Counterbalance Adjustable

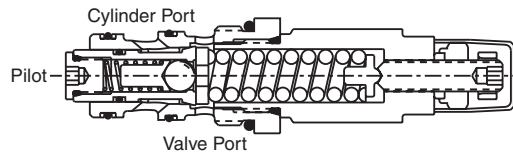

MHC-022-V*N* Vented Counterbalance Non-Adjustable

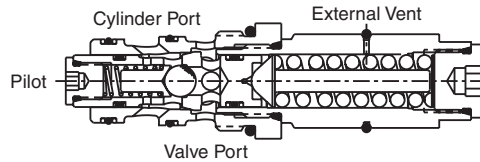

Performance Curve

Flow vs. Pressure Drop (Through cartridge only)

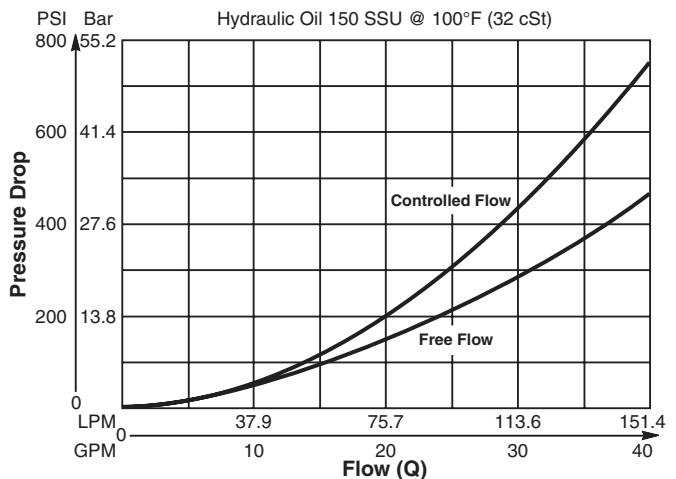

Dimensions Millimeters (Inches)

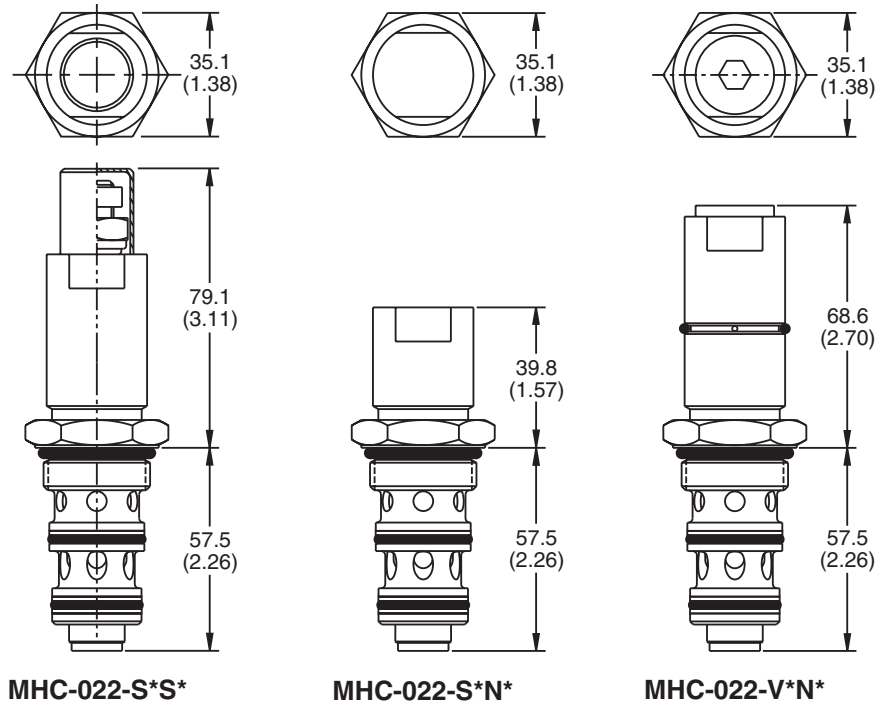

MHC-022-S*S*

MHC-022-S*N*

MHC-022-V*N*

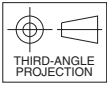

Torque Values
 8-9 Nm (6-7 lb. ft.)
 Typical for all

Ordering Information

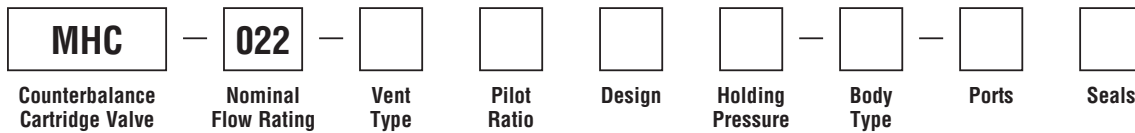

Code	Nominal Flow Rating
022	93.75 LPM (25 GPM)

Code	Pilot Ratio
A	Equal Area (1:1)
C	5:1 (Standard)
J	10:1

Code	Holding Pressure
C	Equal Area 34.5 Bar (500 PSI) Crack
E	103.4 Bar (1500 PSI) Shim adjustable version only
H	210 Bar (3000 PSI) Standard version
J	240 Bar (3500 PSI)
K	350 Bar (5000 PSI) 10:1 only

Code	Body Type	Part Number
Omit	No Body	
A	Single	MHC-022-A-53
D	Dual	MHC-022-D-53

Code	Vent Type
S	Standard (non-vented)
V	Vented

Code	Design
S	Standard with tamper resistant cap (adjustable)
N	Shimmed (non-adjustable)

Code	Ports
00	No Ports
52	SAE-8 through port
53	SAE-10 through port

Code	Seals / Kits
B	Nitrile / 712226
F	Fluorocarbon / TBD

Technical Information

- CV Check Valves
- SH Shuttle Valves
- LM Load/Motor Controls
- FC Flow Controls
- PC Pressure Controls
- LE Logic Elements
- DC Directional Controls
- MV Manual Valves
- SV Solenoid Valves
- PV Proportional Valves
- CE Coils & Electronics
- BC Bodies & Cavities
- TD Technical Data

General Description

Threaded Cartridge Style Counterbalance Valve. Pilot assisted, designed for motion control applications. For additional information see Technical Tips on pages LM1-LM4.

Features

- Poppet construction for minimal leakage
- Incorporates direct acting relief valve for overload protection
- Includes reverse check valve within body, saving space and minimizing installation cost
- Can be directly mounted into cylinder eliminating requirement for manifold block
- Fully sealed pilot for high efficiency and accurate pilot ratio
- Two pilot ratios available, 4.5:1 for cylinders and 8:1 for motor control
- Adjustable and tamper resistant versions available
- Preset version is tamper resistant and compact
- All external parts zinc plated

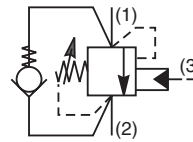
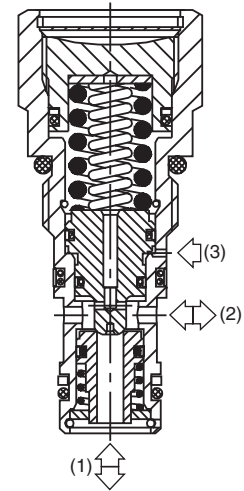

Specifications

Rated Flow	E2A020 14 LPM (3.7 GPM) E2B020 20 LPM (5.3 GPM)
Pressure	50 - 420 Bar (725 - 6000 PSI)
Sensitivity: Pressure/Turn	E2A020 113 Bar (1640 PSI) E2B020 84 Bar (1220 PSI)
Pilot Ratio	E2A020 - 8 : 1 E2B020 - 4.5 : 1
Cartridge Material	All parts steel. All operating parts hardened steel.
Operating Temp. Range/Seals	-40°C to +93.3°C (Nitrile) (-40°F to +200°F) -31.7°C to +121.1°C (Fluorocarbon) (-25°F to +250°F)
Fluid Compatibility/Viscosity	Mineral-based or synthetic with lubricating properties at viscosities of 45 to 2000 SSU (6 to 420 cSt)
Filtration	ISO Code 16/13, SAE Class 4 or better
Approx. Weight	0.08 kg (0.17 lbs.)
Cavity	53-1 (See BC Section for more details)

Performance Curves

Relief & Pilot Performance 1 to 2

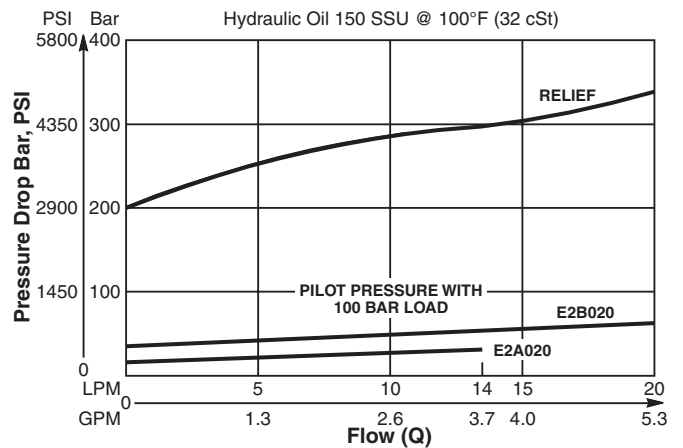

Pressure Drop vs Flow

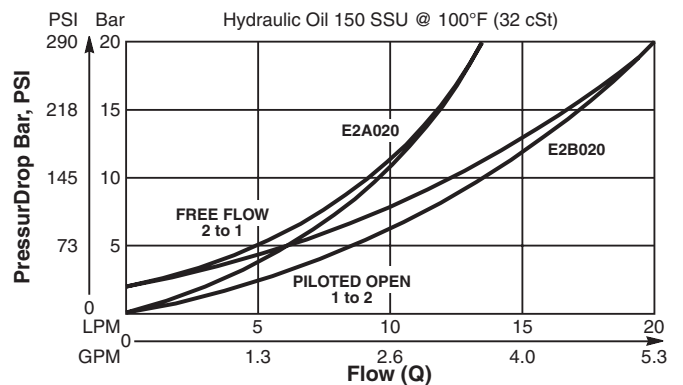

Dimensions Millimeters (Inches)

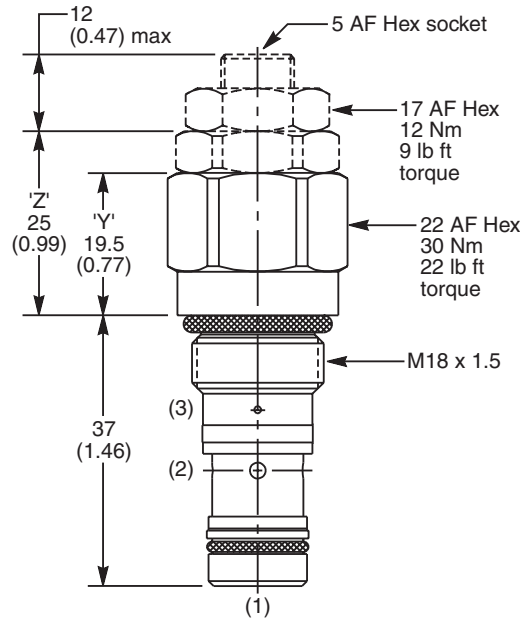

Ordering Information

E2		020			
Load Control Valve	Pilot Ratio	Adjustment Style	Cracking Pressure	Seals	

Code	Pilot Ratio
A	8 : 1
B	4.5 : 1

Code	Cracking Pressure
	Omit for no setting (Standard)* Specify setting if required

**Standard valve is set to crack at 215 Bar (3120 PSI). Valve to be set to 1.3 times maximum load induced pressure.*

Code	Adjustment Style / Kit No.
Z	Screw Adjust
T	Tamper Resistant (TC1125)
Y	Preset (Standard)

Code	Seals / Kit No.
N	Nitrile, Buna-N (Std.) / (SK30087N-1)
V	Fluorocarbon / (SK30087V-1)

Order Bodies Separately

LB10		
Line Body	Porting	Body Material

Code	Porting
310	3/8" BSP (main) 1/4" BSP (aux)
318	3/8" SAE (main) 1/4" SAE (aux)
312	3/8" BSP Dual Cavity
319	3/8" SAE Dual Cavity

Code	Body Material
A	Aluminum
S	Steel

- CV** Check Valves
- SH** Shuttle Valves
- LM** Load/Motor Controls
- FC** Flow Controls
- PC** Pressure Controls
- LE** Logic Elements
- DC** Directional Controls
- MV** Manual Valves
- SV** Solenoid Valves
- PV** Proportional Valves
- CE** Coils & Electronics
- BC** Bodies & Cavities
- TD** Technical Data

Technical Information

- CV Check Valves
- SH Shuttle Valves
- LM Load/Motor Controls
- FC Flow Controls
- PC Pressure Controls
- LE Logic Elements
- DC Directional Controls
- MV Manual Valves
- SV Solenoid Valves
- PV Proportional Valves
- CE Coils & Electronics
- BC Bodies & Cavities
- TD Technical Data

General Description

Threaded Cartridge Style Counterbalance Valve. Pilot assisted, designed for motion control applications. For additional information see Technical Tips on pages LM1-LM4.

Features

- Poppet construction for minimal leakage
- Incorporates direct acting relief valve for overload protection
- Includes reverse check valve within body, saving space and minimizing installation cost
- Excellent control and very good stability
- Three pilot ratios available, 1.75:1 and 3:1 for cylinders and 8:1 for motor control
- Hardened working parts for maximum durability
- Adjustable, preset and tamper resistant versions available
- Preset version is tamper resistant and compact
- All external parts zinc plated

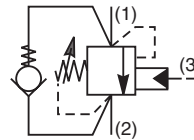
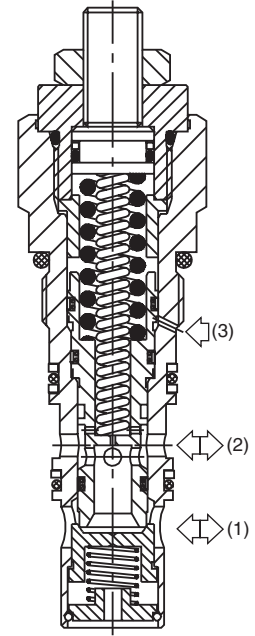
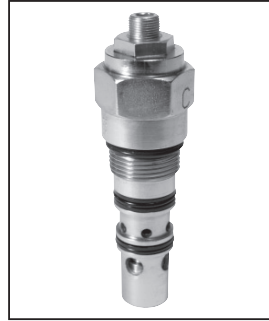

Specifications

Rated Flow	60 LPM (15.9 GPM)
Pressure	50 - 350 Bar (725 - 5000 PSI)
Sensitivity: Pressure/Turn	99 Bar (1435 PSI)
Pilot Ratio	E2A040 - 8 : 1 E2B040 - 3 : 1 E2H040 - 1.75 : 1
Cartridge Material	All parts steel. All operating parts hardened steel.
Operating Temp. Range/Seals	-40°C to +93.3°C (Nitrile) (-40°F to +200°F) -31.7°C to +121.1°C (Fluorocarbon) (-25°F to +250°F)
Fluid Compatibility/ Viscosity	Mineral-based or synthetic with lubricating properties at viscosities of 45 to 2000 SSU (6 to 420 cSt)
Filtration	ISO Code 16/13, SAE Class 4 or better
Approx. Weight	0.27 kg (0.60 lbs.)
Cavity	68-1 (See BC Section for more details)

Performance Curves

Relief & Pilot Performance 1 to 2

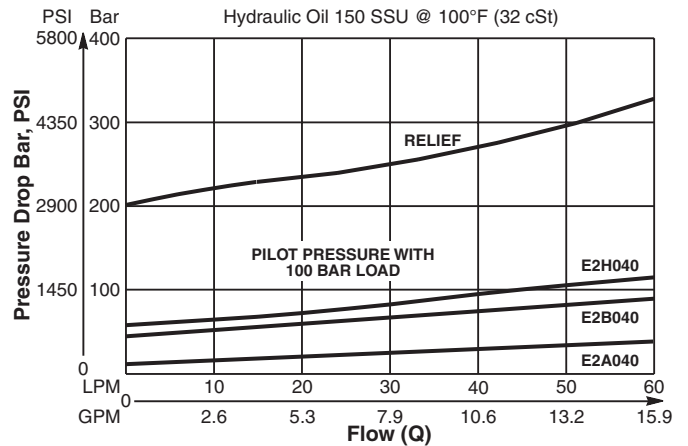

Pressure Drop vs Flow

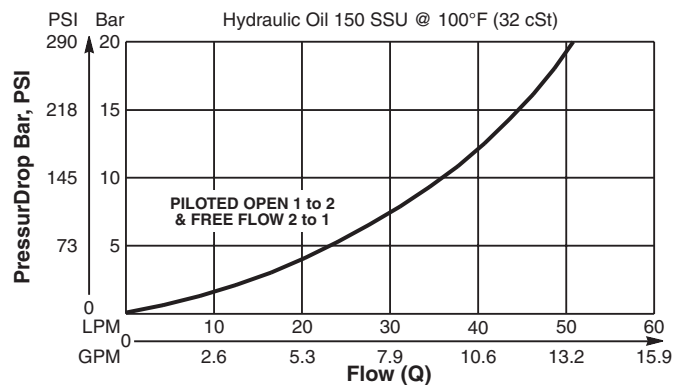

Dimensions Millimeters (Inches)

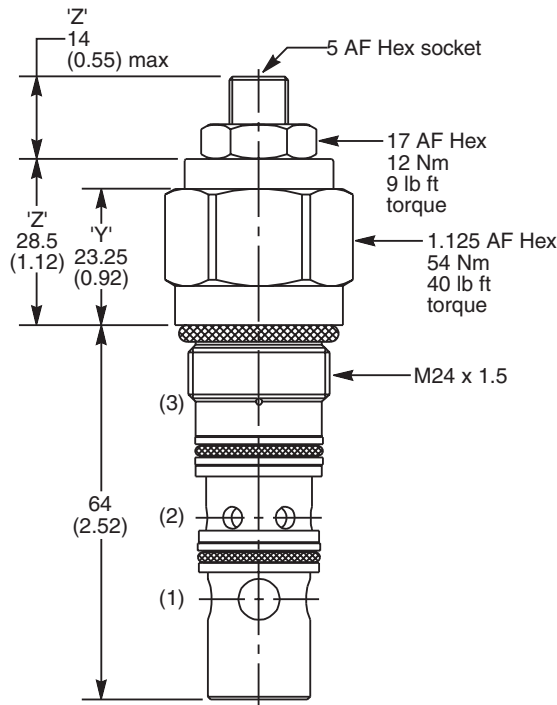

Ordering Information

E2		040			
Load Control Valve	Pilot Ratio	Adjustment Style	Cracking Pressure	Seals	

Code	Pilot Ratio
A	8 : 1
B	3 : 1
H	1.75 : 1

Code	Cracking Pressure
	Omit for no setting (Standard)* Specify setting if required Y: Setting must be specified

**Standard valve is set to crack at 215 Bar (3120 PSI). Valve to be set to 1.3 times maximum load induced pressure.*

Code	Adjustment Style / Kit No.
Z	Screw Adjust (Standard)
T	Tamper Resistant (TC1125)
Y	Non Adjustable Preset

Code	Seals / Kit No.
N	Nitrile, Buna-N (Std.) / (SK30059N-1)
V	Fluorocarbon / (SK30059V-1)

Order Bodies Separately

LB10		
Line Body	Porting	Body Material

Code	Porting
251	1/2" BSP (main) 1/4" BSP (aux)
253	1/2" SAE (main) 1/4" SAE (aux)
259	1/2" BSP Dual Cavity
261	1/2" SAE Dual Cavity

Code	Body Material
A	Aluminum
S	Steel

- CV** Check Valves
- SH** Shuttle Valves
- LM** Load/Motor Controls
- FC** Flow Controls
- PC** Pressure Controls
- LE** Logic Elements
- DC** Directional Controls
- MV** Manual Valves
- SV** Solenoid Valves
- PV** Proportional Valves
- CE** Coils & Electronics
- BC** Bodies & Cavities
- TD** Technical Data

Technical Information

- CV** Check Valves
- SH** Shuttle Valves
- LM** Load/Motor Controls
- FC** Flow Controls
- PC** Pressure Controls
- LE** Logic Elements
- DC** Directional Controls
- MV** Manual Valves
- SV** Solenoid Valves
- PV** Proportional Valves
- CE** Coils & Electronics
- BC** Bodies & Cavities
- TD** Technical Data

General Description

Threaded Cartridge Style Counterbalance Valve. Pilot assisted, designed for motion control applications. For additional information see Technical Tips on pages LM1-LM4.

Features

- Poppet construction for minimal leakage
- Incorporates direct acting relief valve for overload protection
- Includes reverse check valve within body, saving space and minimizing installation cost
- Fully sealed pilot for high efficiency and accurate pilot ratio
- Four pilot ratios available, 1.5:1, 2.3:1, 3:1 and 4.5:1
- Hardened working parts for maximum durability
- All external parts zinc plated

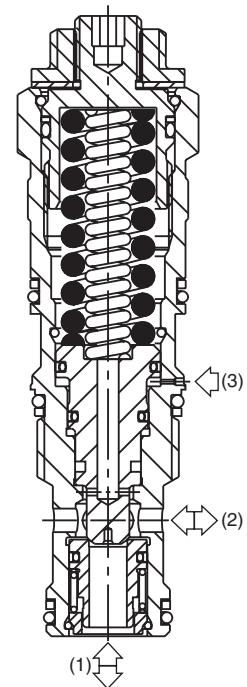
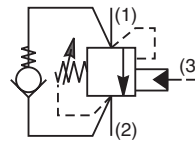
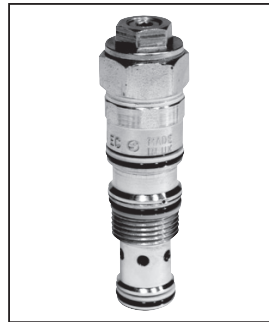

Specifications

Rated Flow	60 LPM (16 GPM)
Pressure	40 - 350 Bar (580 - 5000 PSI)
Sensitivity: Pressure/Turn	104 Bar (1508 PSI)
Pilot Ratio	E2E1 - 1.5 : 1 E2G1 - 2.3 : 1 E2K1 - 3 : 1 E2M1 - 4.5 : 1
Cartridge Material	All parts steel. All operating parts hardened steel.
Operating Temp. Range/Seals	-40°C to +93.3°C (Nitrile) (-40°F to +200°F) -31.7°C to +121.1°C (Fluorocarbon) (-25°F to +250°F)
Fluid Compatibility/ Viscosity	Mineral-based or synthetic with lubricating properties at viscosities of 45 to 2000 SSU (6 to 420 cSt)
Filtration	ISO Code 16/13, SAE Class 4 or better
Approx. Weight	0.17 kg (0.37 lbs.)
Cavity	CAVT11A (See BC Section for more details)

Performance Curves

Relief & Pilot Performance 1 to 2

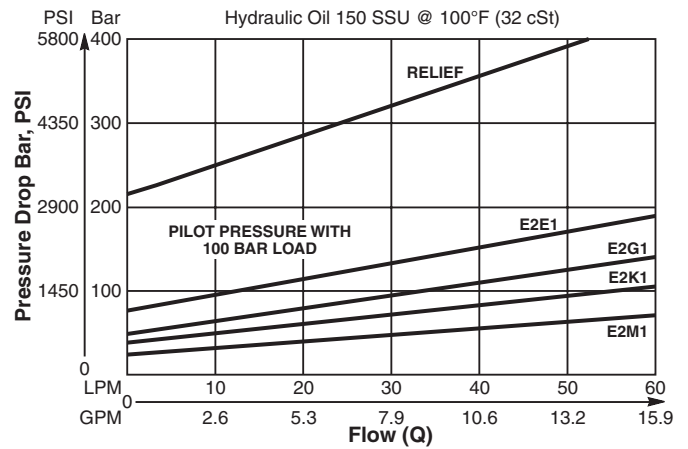

Pressure Drop vs Flow

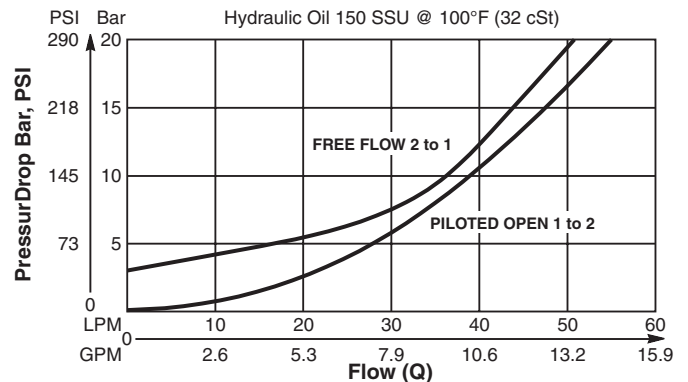

Dimensions Millimeters (Inches)

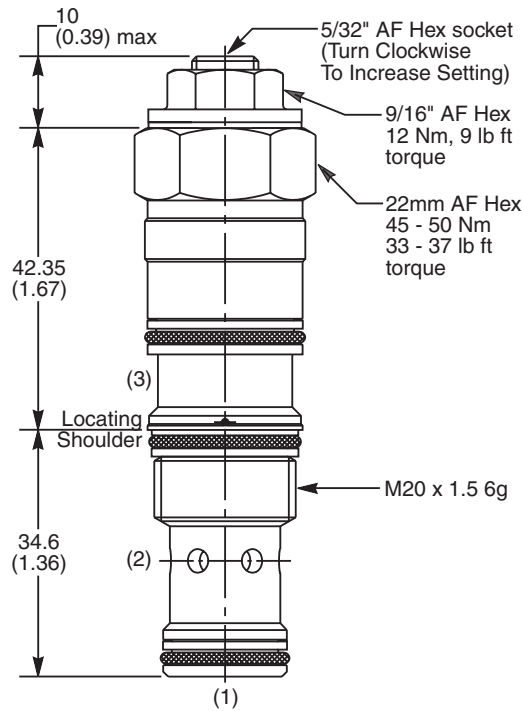

Ordering Information

E2		1			
Load Control Valve	Pilot Ratio	Adjustment Style	Cracking Pressure	Seals	

Code	Pilot Ratio
E	1.5 : 1
G	2.3 : 1
K	3 : 1
M	4.5 : 1

Code	Cracking Pressure
	Omit for no setting (Standard)* Specify setting if required

**Standard valve is set to crack at 215 Bar (3120 PSI). Valve to be set to 1.3 times maximum load induced pressure.*

Code	Adjustment Style / Kit No.
Z	Screw Adjust (Standard)
T	Tamper Resistant (TC1131)

Code	Seals / Kit No.
N	Nitrile, Buna-N (Std.) / (SK30700N-1)
V	Fluorocarbon / (SK30700V-1)

Order Bodies Separately

LB10		
Line Body	Porting	Body Material

Code	Porting
826	1/2" BSP (main) 1/4" BSP (aux)
825	1/2" SAE (main) 1/4" SAE (aux)
828	1/2" BSP Dual Cavity
827	1/2" SAE Dual Cavity

Code	Body Material
A	Aluminum
S	Steel

Technical Information

- CV Check Valves
- SH Shuttle Valves
- LM Load/Motor Controls
- FC Flow Controls
- PC Pressure Controls
- LE Logic Elements
- DC Directional Controls
- MV Manual Valves
- SV Solenoid Valves
- PV Proportional Valves
- CE Coils & Electronics
- BC Bodies & Cavities
- TD Technical Data

General Description

Threaded Cartridge Style Counterbalance Valve. Semi-Restrictive Ports 2 to 3. Pilot assisted, designed for motion control applications. For additional information see Technical Tips on pages LM1-LM4.

Features

- Poppet construction for minimal leakage
- Incorporates direct acting relief valve for overload protection
- Includes reverse check valve within body, saving space and minimizing installation cost
- Fully sealed pilot for high efficiency and accurate pilot ratio
- Four pilot ratios available, 1.5:1, 2.3:1, 3:1 and 4.5:1
- Hardened working parts for maximum durability
- All external parts zinc plated

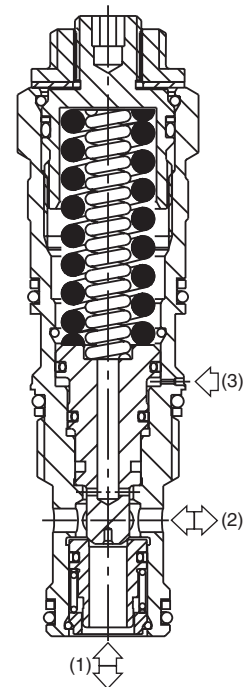
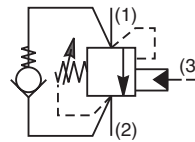
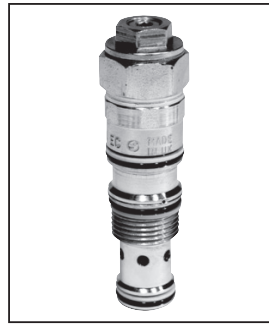

Specifications

Rated Flow	Free flow 60 LPM (16 GPM) Piloted open flow 45 LPM (12 GPM)
Pressure	40 - 350 Bar (580 - 5000 PSI)
Sensitivity: Pressure/Turn	104 Bar (1508 PSI)
Pilot Ratio	E2E1S - 1.5 : 1 E2G1S - 2.3 : 1 E2K1S - 3 : 1 E2M1S - 4.5 : 1
Cartridge Material	All parts steel. All operating parts hardened steel.
Operating Temp. Range/Seals	-40°C to +93.3°C (Nitrile) (-40°F to +200°F) -31.7°C to +121.1°C (Fluorocarbon) (-25°F to +250°F)
Fluid Compatibility/ Viscosity	Mineral-based or synthetic with lubricating properties at viscosities of 45 to 2000 SSU (6 to 420 cSt)
Filtration	ISO Code 16/13, SAE Class 4 or better
Approx. Weight	0.17 kg (0.37 lbs.)
Cavity	CAVT11A (See BC Section for more details)

Performance Curves

Relief & Pilot Performance 1 to 2

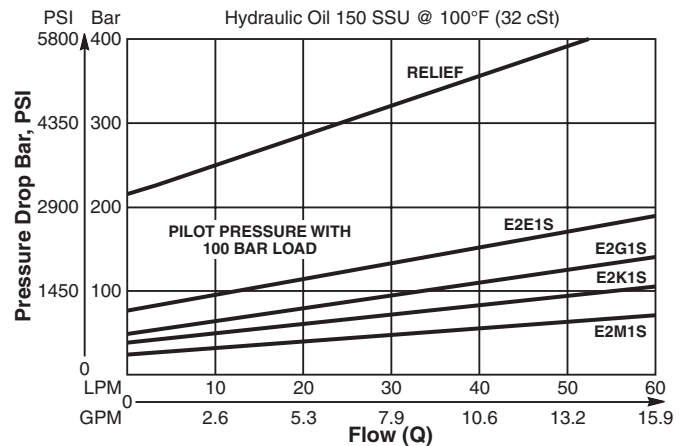

Pressure Drop vs Flow

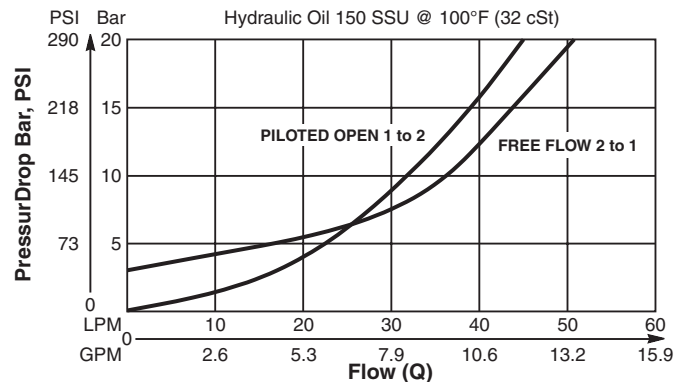

Dimensions Millimeters (Inches)

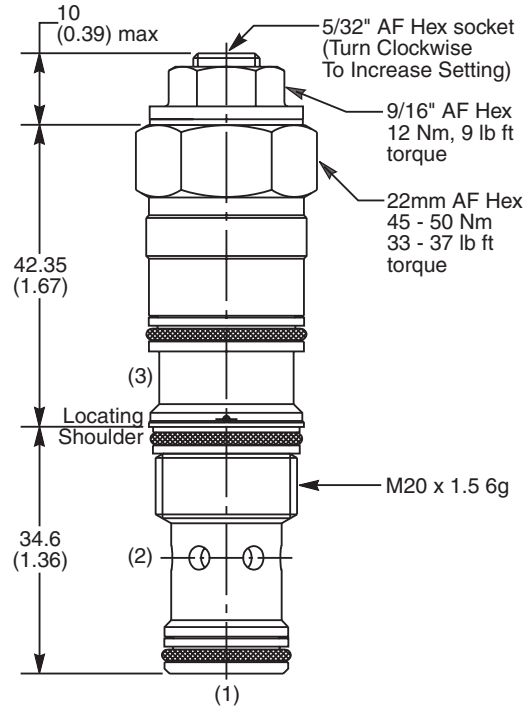

Ordering Information

E2		1S			
Load Control Valve	Pilot Ratio	Adjustment Style	Cracking Pressure	Seals	

Code	Pilot Ratio
E	1.5 : 1
G	2.3 : 1
K	3 : 1
M	4.5 : 1

Code	Cracking Pressure
	Omit for no setting (Standard)* Specify setting if required

**Standard valve is set to crack at 215 Bar (3120 PSI). Valve to be set to 1.3 times maximum load induced pressure.*

Code	Adjustment Style / Kit No.
Z	Screw Adjust (Standard)
T	Tamper Resistant (TC1131)

Code	Seals / Kit No.
N	Nitrile, Buna-N (Std.) / (SK30700N-1)
V	Fluorocarbon / (SK30700V-1)

Order Bodies Separately

LB10		
Line Body	Porting	Body Material

Code	Porting
826	1/2" BSP (main) 1/4" BSP (aux)
825	1/2" SAE (main) 1/4" SAE (aux)
828	1/2" BSP Dual Cavity
827	1/2" SAE Dual Cavity

Code	Body Material
A	Aluminum
S	Steel

- CV** Check Valves
- SH** Shuttle Valves
- LM** Load/Motor Controls
- FC** Flow Controls
- PC** Pressure Controls
- LE** Logic Elements
- DC** Directional Controls
- MV** Manual Valves
- SV** Solenoid Valves
- PV** Proportional Valves
- CE** Coils & Electronics
- BC** Bodies & Cavities
- TD** Technical Data

Technical Information

- CV Check Valves
- SH Shuttle Valves
- LM Load/Motor Controls
- FC Flow Controls
- PC Pressure Controls
- LE Logic Elements
- DC Directional Controls
- MV Manual Valves
- SV Solenoid Valves
- PV Proportional Valves
- CE Coils & Electronics
- BC Bodies & Cavities
- TD Technical Data

General Description

Threaded Cartridge Style Counterbalance Valve. Restrictive Ports 2 to 3. Pilot assisted, designed for motion control applications. For additional information see Technical Tips on pages LM1-LM4.

Features

- Poppet construction for minimal leakage
- Incorporates direct acting relief valve for overload protection
- Includes reverse check valve within body, saving space and minimizing installation cost
- Fully sealed pilot for high efficiency and accurate pilot ratio
- Two pilot ratios available, 3:1 and 4.5:1
- Hardened working parts for maximum durability
- All external parts zinc plated

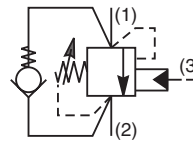
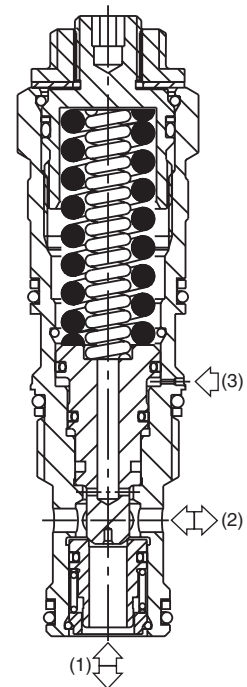
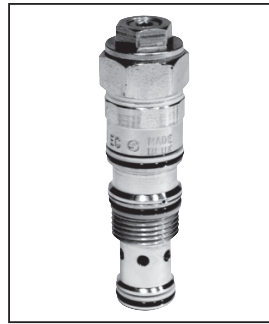

Specifications

Rated Flow	Free flow 60 LPM (16 GPM) Pilot open flow 38 LPM (10 GPM)
Pressure	90 - 350 Bar (1305 - 5000 PSI)
Sensitivity: Pressure/Turn	104 Bar (1508 PSI)
Pilot Ratio	E2K1R - 3 : 1 E2M1R - 4.5 : 1
Cartridge Material	All parts steel. All operating parts hardened steel.
Operating Temp. Range/Seals	-40°C to +93.3°C (Nitrile) (-40°F to +200°F) -31.7°C to +121.1°C (Fluorocarbon) (-25°F to +250°F)
Fluid Compatibility/Viscosity	Mineral-based or synthetic with lubricating properties at viscosities of 45 to 2000 SSU (6 to 420 cSt)
Filtration	ISO Code 16/13, SAE Class 4 or better
Approx. Weight	0.17 kg (0.37 lbs.)
Cavity	CAVT11A (See BC Section for more details)

Performance Curves

Relief & Pilot Performance 1 to 2

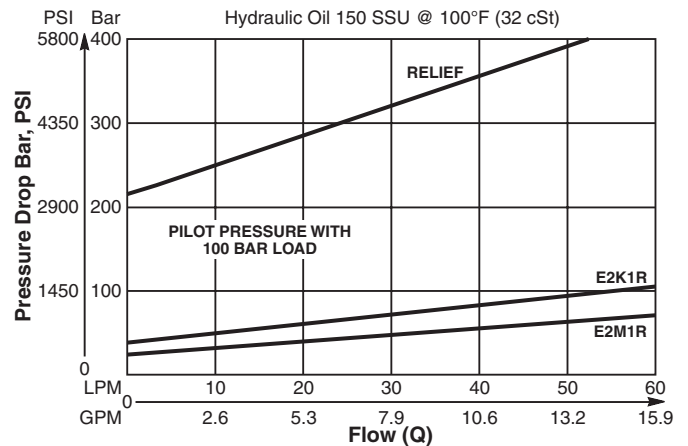

Pressure Drop vs Flow

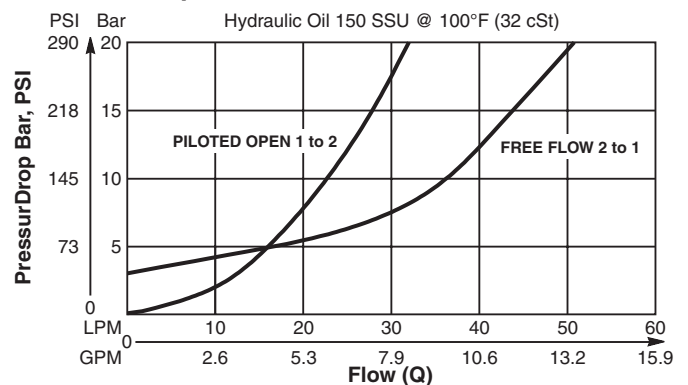

Dimensions Millimeters (Inches)

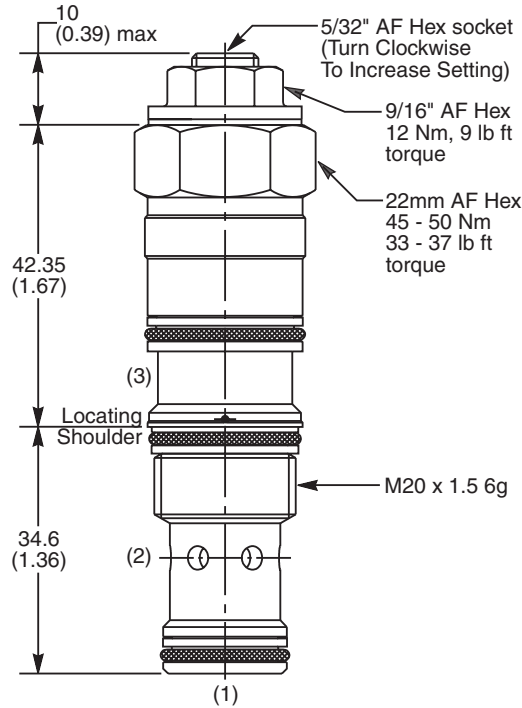

Ordering Information

E2		1R			
Load Control Valve	Pilot Ratio	Adjustment Style	Cracking Pressure	Seals	

Code	Pilot Ratio
K	3 : 1
M	4.5 : 1

Code	Adjustment Style / Kit No.
Z	Screw Adjust (Standard)
T	Tamper Resistant (TC1131)

Code	Cracking Pressure
	Omit for no setting (Standard)* Specify setting if required

**Standard valve is set to crack at 215 Bar (3120 PSI). Valve to be set to 1.3 times maximum load induced pressure.*

Code	Seals / Kit No.
N	Nitrile, Buna-N (Std.) / (SK30700N-1)
V	Fluorocarbon / (SK30700V-1)

Order Bodies Separately

LB10		
Line Body	Porting	Body Material

Code	Porting
826	1/2" BSP (main) 1/4" BSP (aux)
825	1/2" SAE (main) 1/4" SAE (aux)
828	1/2" BSP Dual Cavity
827	1/2" SAE Dual Cavity

Code	Body Material
A	Aluminum
S	Steel

- CV** Check Valves
- SH** Shuttle Valves
- LM** Load/Motor Controls
- FC** Flow Controls
- PC** Pressure Controls
- LE** Logic Elements
- DC** Directional Controls
- MV** Manual Valves
- SV** Solenoid Valves
- PV** Proportional Valves
- CE** Coils & Electronics
- BC** Bodies & Cavities
- TD** Technical Data

Technical Information

- CV** Check Valves
- SH** Shuttle Valves
- LM** Load/Motor Controls
- FC** Flow Controls
- PC** Pressure Controls
- LE** Logic Elements
- DC** Directional Controls
- MV** Manual Valves
- SV** Solenoid Valves
- PV** Proportional Valves
- CE** Coils & Electronics
- BC** Bodies & Cavities
- TD** Technical Data

General Description

Threaded Cartridge Style Counterbalance Valve. Pilot assisted, designed for motion control applications. For additional information see Technical Tips on pages LM1-LM4.

Features

- Poppet construction for minimal leakage
- Incorporates direct acting relief valve for overload protection
- Includes reverse check valve within body, saving space and minimizing installation cost
- Excellent control and very good stability
- Four pilot ratios available, 1.75:1, 3:1, and 5:1 for cylinders and 8:1 for motor control
- Hardened working parts for maximum durability
- Adjustable and tamper resistant versions also available
- All external parts zinc plated

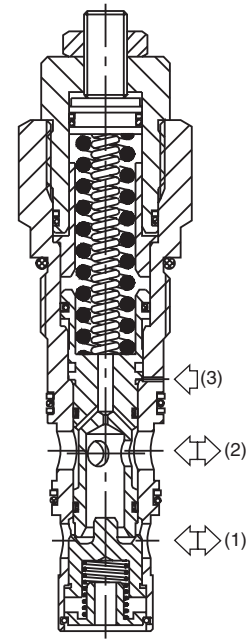
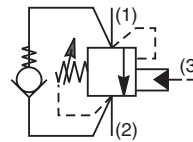

Specifications

Rated Flow	120 LPM (32 GPM)
Pressure	50 - 350 Bar (725 - 5000 PSI)
Sensitivity: Pressure/Turn	44 Bar (640 PSI)
Pilot Ratio	E2A060 - 8 : 1 E2B060 - 3 : 1 E2H060 - 1.75 : 1 E2J060 - 5 : 1
Cartridge Material	All parts steel. All operating parts hardened steel.
Operating Temp. Range/Seals	-40°C to +93.3°C (Nitrile) (-40°F to +200°F) -31.7°C to +121.1°C (Fluorocarbon) (-25°F to +250°F)
Fluid Compatibility/ Viscosity	Mineral-based or synthetic with lubricating properties at viscosities of 45 to 2000 SSU (6 to 420 cSt)
Filtration	ISO Code 16/13, SAE Class 4 or better
Approx. Weight	0.54 kg (1.19 lbs.)
Cavity	3C (See BC Section for more details)

Performance Curves

Relief & Pilot Performance 1 to 2

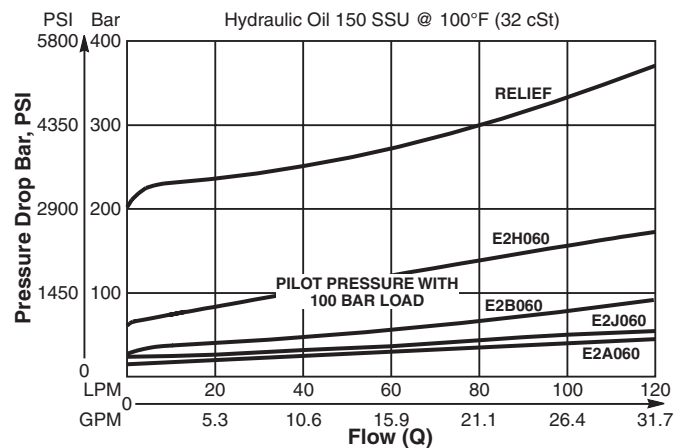

Pressure Drop vs Flow

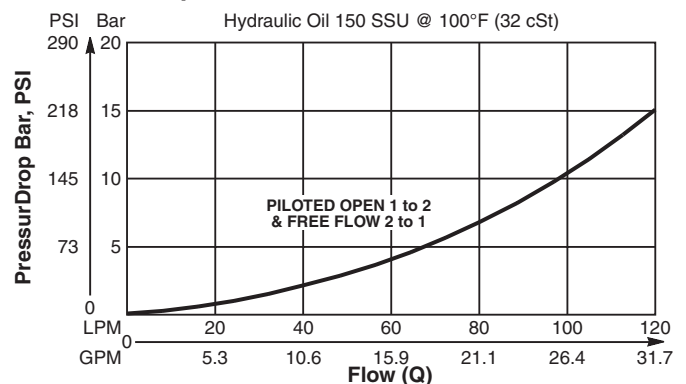

Dimensions Millimeters (Inches)

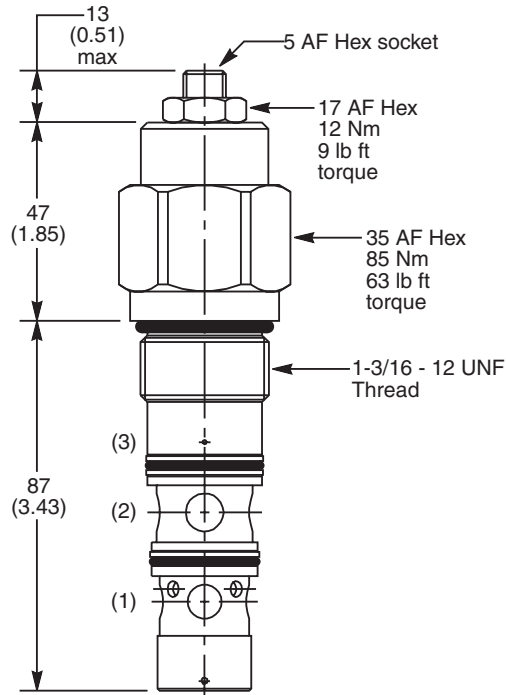

Ordering Information

E2		060			
Load Control Valve	Pilot Ratio	Adjustment Style	Cracking Pressure	Seals	

Code	Pilot Ratio
A	8 : 1
B	3 : 1
H	1.75 : 1
J	5 : 1

Code	Cracking Pressure
	Omit for no setting (Standard)* Specify setting if required

**Standard valve is set to crack at 215 Bar (3120 PSI). Valve to be set to 1.3 times maximum load induced pressure.*

Code	Adjustment Style / Kit No.
Z	Screw Adjust (Standard)
T	Tamper Resistant (TC1125)

Code	Seals / Kit No.
N	Nitrile, Buna-N (Std.) / (SK30008N-1)
V	Fluorocarbon / (SK30008V-1)

Order Bodies Separately

LB10		
Line Body	Porting	Body Material

Code	Porting
039	3/4" BSP (main) 1/4" BSP (aux)
069	1" SAE (main) 1/4" SAE (aux)
034	3/4" BSP Dual Cavity
234	3/4" SAE Dual Cavity

Code	Body Material
A	Aluminum
S	Steel

- CV** Check Valves
- SH** Shuttle Valves
- LM** Load/Motor Controls
- FC** Flow Controls
- PC** Pressure Controls
- LE** Logic Elements
- DC** Directional Controls
- MV** Manual Valves
- SV** Solenoid Valves
- PV** Proportional Valves
- CE** Coils & Electronics
- BC** Bodies & Cavities
- TD** Technical Data

Technical Information

- CV Check Valves
- SH Shuttle Valves
- LM Load/Motor Controls
- FC Flow Controls
- PC Pressure Controls
- LE Logic Elements
- DC Directional Controls
- MV Manual Valves
- SV Solenoid Valves
- PV Proportional Valves
- CE Coils & Electronics
- BC Bodies & Cavities
- TD Technical Data

General Description

Threaded Cartridge Style Counterbalance Valve. Pilot assisted, designed for motion control applications. For additional information see Technical Tips on pages LM1-LM4.

Features

- Poppet construction for minimal leakage
- Incorporates direct acting relief valve for overload protection, and reverse check valve, saving space and minimizing installation cost
- Two pilot ratios available, 3:1 for cylinders and 8:1 for motor control
- Hardened working parts for maximum durability
- Adjustable and tamper resistant versions also available
- All external parts zinc plated

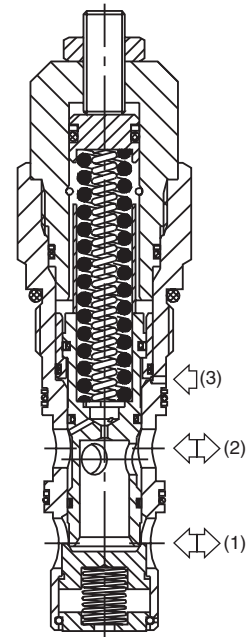
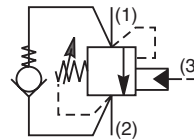
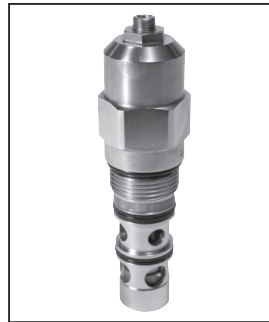

Specifications

Rated Flow	200 LPM (53 GPM)
Pressure	50 - 350 Bar (725 - 5000 PSI)
Sensitivity: Pressure/Turn	34 Bar (493 PSI)
Pilot Ratio	E2A125 - 8 : 1 E2E125 - 3 : 1
Cartridge Material	All parts steel. All operating parts hardened steel.
Operating Temp. Range/Seals	-40°C to +93.3°C (Nitrile) (-40°F to +200°F) -31.7°C to +121.1°C (Fluorocarbon) (-25°F to +250°F)
Fluid Compatibility/ Viscosity	Mineral-based or synthetic with lubricating properties at viscosities of 45 to 2000 SSU (6 to 420 cSt)
Filtration	ISO Code 16/13, SAE Class 4 or better
Approx. Weight	0.75 kg (1.65 lbs.)
Cavity	3M (See BC Section for more details)

Performance Curves

Relief & Pilot Performance 1 to 2

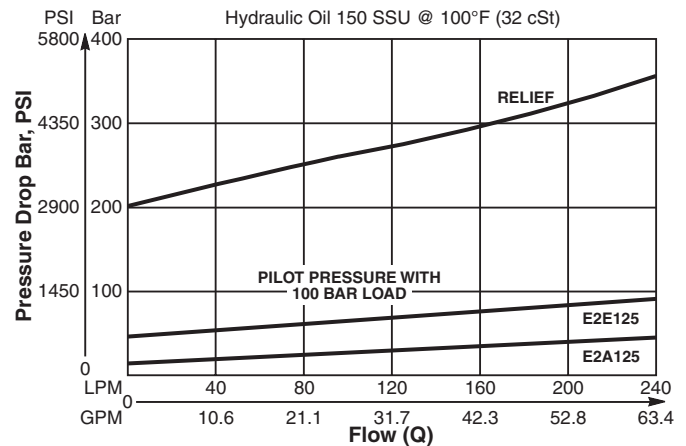

Pressure Drop vs Flow

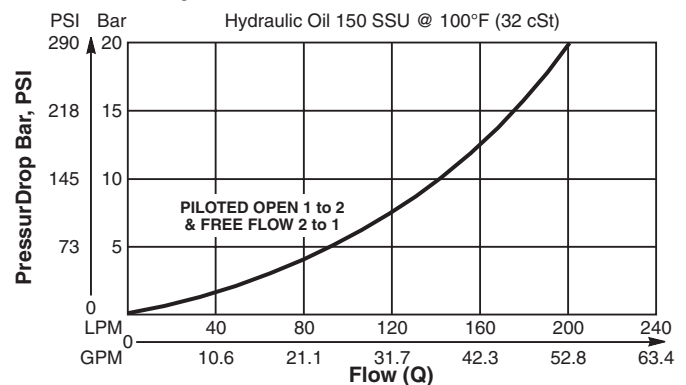

Dimensions Millimeters (Inches)

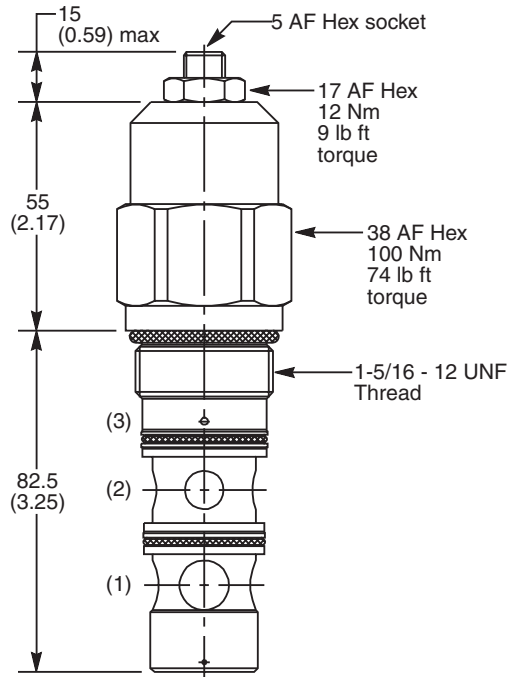

Ordering Information

E2		125			
Load Control Valve	Pilot Ratio		Adjustment Style	Cracking Pressure	Seals

Code	Pilot Ratio
A	8 : 1
E	3 : 1

Code	Cracking Pressure
	Omit for no setting (Standard)* Specify setting if required

**Standard valve is set to crack at 215 Bar (3120 PSI). Valve to be set to 1.3 times maximum load induced pressure.*

Code	Adjustment Style / Kit No.
Z	Screw Adjust (Standard)
T	Tamper Resistant (TC1125)
Y	Non-Adjustable Preset

Code	Seals / Kit No.
N	Nitrile, Buna-N (Std.) / (SK30035N-1)
V	Fluorocarbon / (SK30035V-1)

Order Bodies Separately

LB10		
Line Body	Porting	Body Material

Code	Porting
076	1" BSP (main) 1/4" BSP (aux)
078	1" SAE (main) 1/4" SAE (aux)
104	1" BSP Dual Cavity
105	1" SAE Dual Cavity

Code	Body Material
A	Aluminum
S	Steel

- CV** Check Valves
- SH** Shuttle Valves
- LM** Load/Motor Controls
- FC** Flow Controls
- PC** Pressure Controls
- LE** Logic Elements
- DC** Directional Controls
- MV** Manual Valves
- SV** Solenoid Valves
- PV** Proportional Valves
- CE** Coils & Electronics
- BC** Bodies & Cavities
- TD** Technical Data

Technical Information

- CV** Check Valves
- SH** Shuttle Valves
- LM** Load/Motor Controls
- FC** Flow Controls
- PC** Pressure Controls
- LE** Logic Elements
- DC** Directional Controls
- MV** Manual Valves
- SV** Solenoid Valves
- PV** Proportional Valves
- CE** Coils & Electronics
- BC** Bodies & Cavities
- TD** Technical Data

General Description

Threaded Cartridge Style Counterbalance Valve. Pilot assisted, designed for motion control applications. For additional information see Technical Tips on pages LM1-LM4.

Features

- Poppet construction for minimal leakage
- Incorporates direct acting relief valve for overload protection, and reverse check valve, saving space and minimizing installation cost
- Two pilot ratios available, 3:1 for cylinders and 8:1 for motor control
- Hardened working parts for maximum durability
- Adjustable and tamper resistant versions also available
- All external parts zinc plated

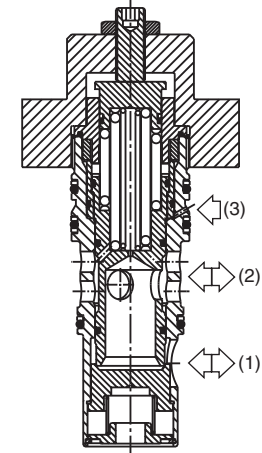
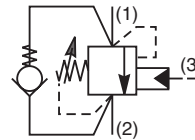
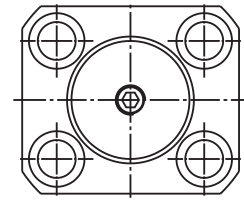

Specifications

Rated Flow	350 LPM (92 GPM)
Pressure	50 - 350 Bar (725 - 5000 PSI)
Sensitivity: Pressure/Turn	45 Bar (653 PSI)
Pilot Ratio	E2A300 - 8 : 1 E2C300 - 3 : 1
Cartridge Material	All parts steel. All operating parts hardened steel.
Operating Temp. Range/Seals	-40°C to +93.3°C (Nitrile) (-40°F to +200°F) -31.7°C to +121.1°C (Fluorocarbon) (-25°F to +250°F)
Fluid Compatibility/Viscosity	Mineral-based or synthetic with lubricating properties at viscosities of 45 to 2000 SSU (6 to 420 cSt)
Filtration	ISO Code 16/13, SAE Class 4 or better
Approx. Weight	1.44 kg (3.17 lbs.)
Cavity	3K (See BC Section for more details)

Performance Curves

Relief & Pilot Performance 1 to 2

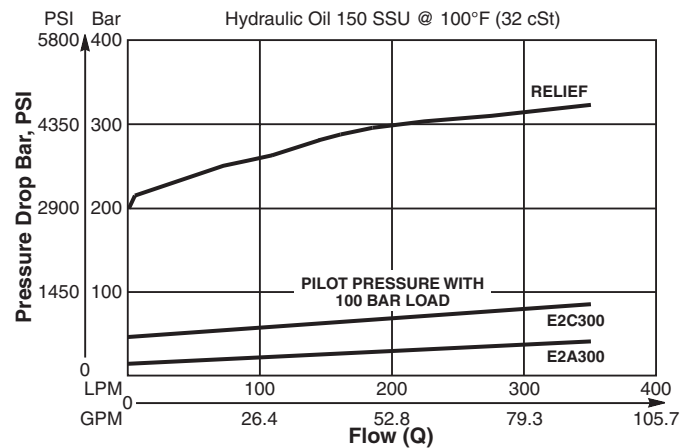

Pressure Drop vs Flow

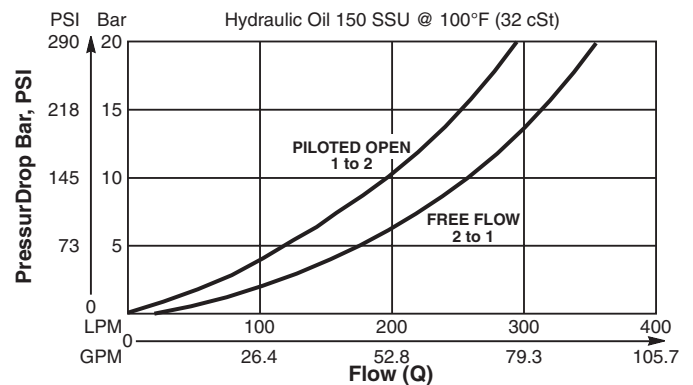

Dimensions Millimeters (Inches)

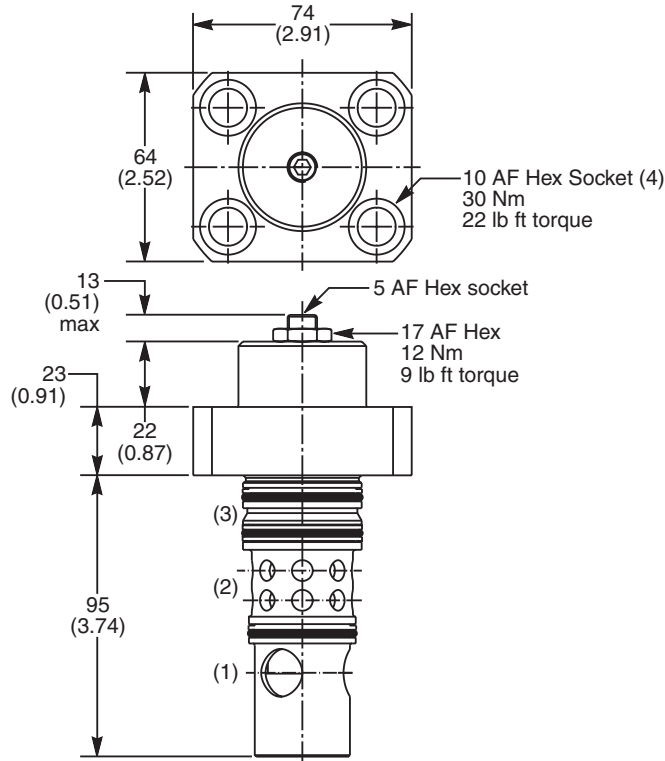

Ordering Information

E2		300			
Load Control Valve	Pilot Ratio		Adjustment Style	Cracking Pressure	Seals

Code	Pilot Ratio
A	8 : 1
C	3 : 1

Code	Cracking Pressure
	Omit for no setting (Standard)* Specify setting if required

**Standard valve is set to crack at 215 Bar (3120 PSI). Valve to be set to 1.3 times maximum load induced pressure.*

Code	Adjustment Style / Kit No.
Z	Screw Adjust
T	Tamper Resistant (TC1125)

Code	Seals / Kit No.
N	Nitrile, Buna-N (Std.) / (SK30022N-1)
V	Fluorocarbon / (SK30022V-1)

Order Bodies Separately

LB10		
Line Body	Porting	Body Material

Code	Porting
089	1-1/4" BSP (main) 1/4" BSP (aux)

Code	Body Material
A	Aluminum
S	Steel

- CV** Check Valves
- SH** Shuttle Valves
- LM** Load/Motor Controls
- FC** Flow Controls
- PC** Pressure Controls
- LE** Logic Elements
- DC** Directional Controls
- MV** Manual Valves
- SV** Solenoid Valves
- PV** Proportional Valves
- CE** Coils & Electronics
- BC** Bodies & Cavities
- TD** Technical Data

Technical Information

- CV Check Valves
- SH Shuttle Valves
- LM Load/Motor Controls
- FC Flow Controls
- PC Pressure Controls
- LE Logic Elements
- DC Directional Controls
- MV Manual Valves
- SV Solenoid Valves
- PV Proportional Valves
- CE Coils & Electronics
- BC Bodies & Cavities
- TD Technical Data

General Description

Threaded Cartridge Style Counterbalance Valve. Pilot assisted, designed for motion control applications. For additional information see Technical Tips on pages LM1-LM4.

Features

- Spring chamber isolated from system backpressure by double seal, eliminating vent port leakage and need for separate drain line
- Poppet construction for minimal leakage
- Incorporates direct acting relief valve for overload protection
- Includes reverse check valve within body
- Small and compact, can be fitted directly into cylinder
- Adjustable and tamper resistant versions available
- All external parts zinc plated

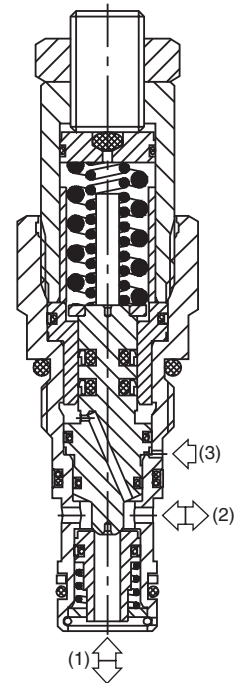
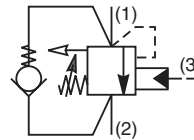
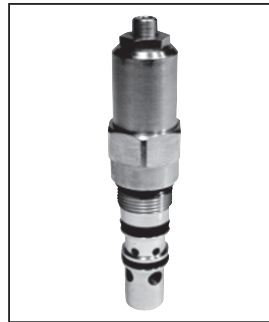

Specifications

Rated Flow	20 LPM (5.3 GPM)
Pressure	50 - 420 Bar (725 - 6000 PSI)
Sensitivity: Pressure/Turn	84 Bar (1220 PSI)
Pilot Ratio	4.5 : 1
Cartridge Material	All parts steel. All operating parts hardened steel.
Operating Temp. Range/Seals	-40°C to +93.3°C (Nitrile) (-40°F to +200°F) -31.7°C to +121.1°C (Fluorocarbon) (-25°F to +250°F)
Fluid Compatibility/ Viscosity	Mineral-based or synthetic with lubricating properties at viscosities of 45 to 2000 SSU (6 to 420 cSt)
Filtration	ISO Code 16/13, SAE Class 4 or better
Approx. Weight	0.08 kg (0.18 lbs.)
Cavity	53-1 (See BC Section for more details)

Performance Curves

Relief & Pilot Performance 1 to 2

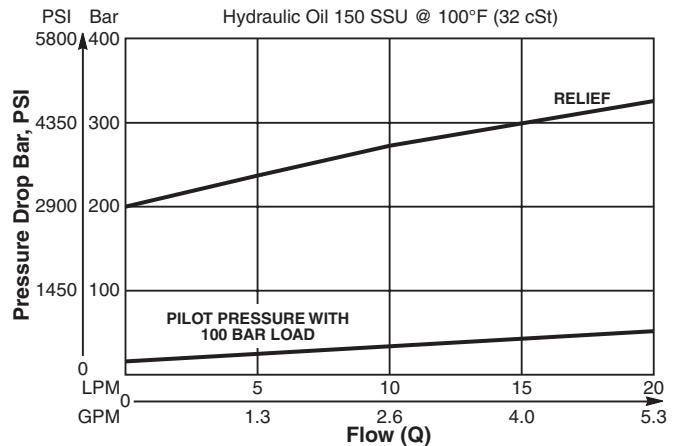

Pressure Drop vs Flow

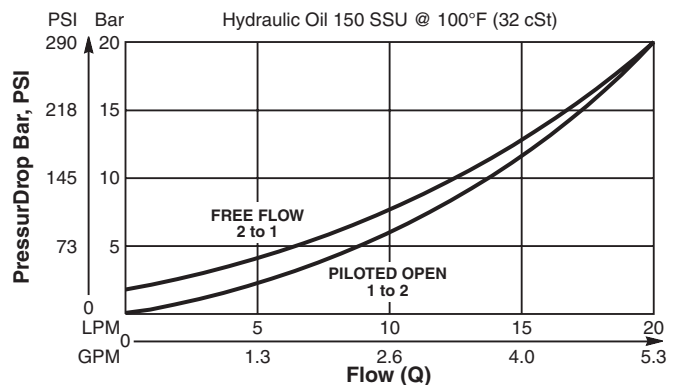

Dimensions Millimeters (Inches)

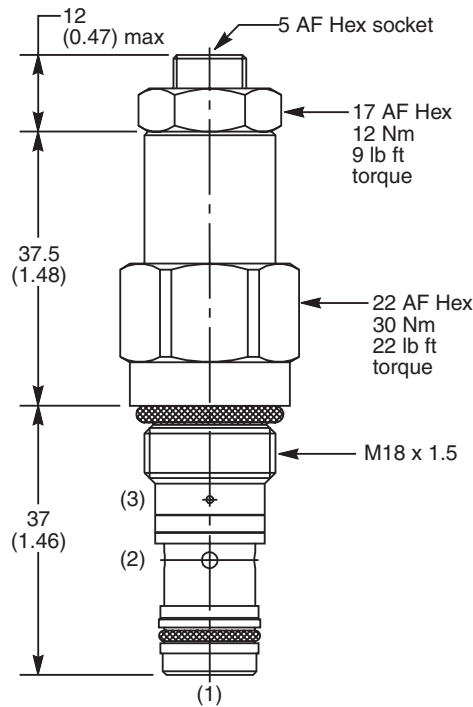

Ordering Information

E6	B	020	<input type="checkbox"/>	<input type="checkbox"/>	<input type="checkbox"/>
Load Control Valve	Pilot Ratio		Adjustment Style	Cracking Pressure	Seals

Code	Pilot Ratio
B	4.5 : 1

Code	Adjustment Style / Kit No.
Z	Screw Adjust (Standard)
T	Tamper Resistant (TC1125)

Code	Cracking Pressure
	Omit for no setting (Standard)* Specify setting if required

**Standard valve is set to crack at 215 Bar (3120 PSI). Valve to be set to 1.3 times maximum load induced pressure.*

Code	Seals / Kit No.
N	Nitrile, Buna-N (Std.) / (SK30087N-1)
V	Fluorocarbon / (SK30087V-1)

Order Bodies Separately

LB10	<input type="checkbox"/>	<input type="checkbox"/>
Line Body	Porting	Body Material

Code	Porting
310	3/8" BSP (main) 1/4" BSP (aux)
318	3/8" SAE (main) 1/4" SAE (aux)
312	3/8" BSP Dual Cavity
319	3/8" SAE Dual Cavity

Code	Body Material
A	Aluminum
S	Steel

- CV** Check Valves
- SH** Shuttle Valves
- LM** Load/Motor Controls
- FC** Flow Controls
- PC** Pressure Controls
- LE** Logic Elements
- DC** Directional Controls
- MV** Manual Valves
- SV** Solenoid Valves
- PV** Proportional Valves
- CE** Coils & Electronics
- BC** Bodies & Cavities
- TD** Technical Data

Technical Information

- CV Check Valves
- SH Shuttle Valves
- LM Load/Motor Controls
- FC Flow Controls
- PC Pressure Controls
- LE Logic Elements
- DC Directional Controls
- MV Manual Valves
- SV Solenoid Valves
- PV Proportional Valves
- CE Coils & Electronics
- BC Bodies & Cavities
- TD Technical Data

General Description

Threaded Cartridge Style Counterbalance Valve. Pilot assisted, designed for motion control applications. For additional information see Technical Tips on pages LM1-LM4.

Features

- Spring chamber isolated from system backpressure by double seal, eliminating vent port leakage and need for separate drain line
- Poppet construction for minimal leakage
- Suitable for remote pilot controlled boomlock applications as per ISO8463
- Incorporates direct acting relief valve for overload protection
- Includes reverse check valve within body
- Hardened working parts for maximum durability
- Adjustable and tamper resistant versions available
- All external parts zinc plated

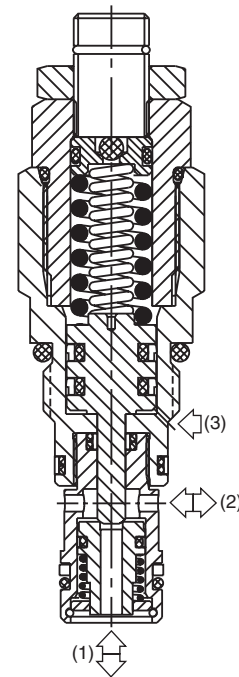
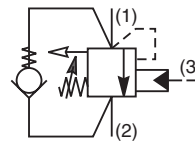
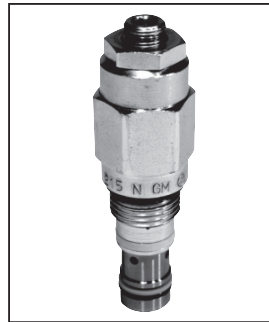

Specifications

Rated Flow	20 LPM (5.3 GPM)
Pressure	100 - 350 Bar (1450 - 5075 PSI)
Sensitivity: Pressure/Turn	114 Bar (1650 PSI)
Pilot Ratio	15 : 1
Cartridge Material	All parts steel. All operating parts hardened steel.
Operating Temp. Range/Seals	-40°C to +93.3°C (Nitrile) (-40°F to +200°F) -31.7°C to +121.1°C (Fluorocarbon) (-25°F to +250°F)
Fluid Compatibility/ Viscosity	Mineral-based or synthetic with lubricating properties at viscosities of 45 to 2000 SSU (6 to 420 cSt)
Filtration	ISO Code 16/13, SAE Class 4 or better
Approx. Weight	0.08 kg (0.18 lbs.)
Cavity	53-1 (See BC Section for more details)

Performance Curves

Relief & Pilot Performance 1 to 2

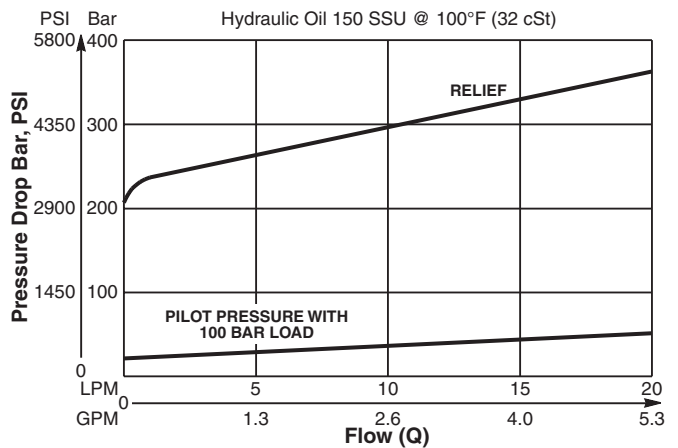

Pressure Drop vs Flow

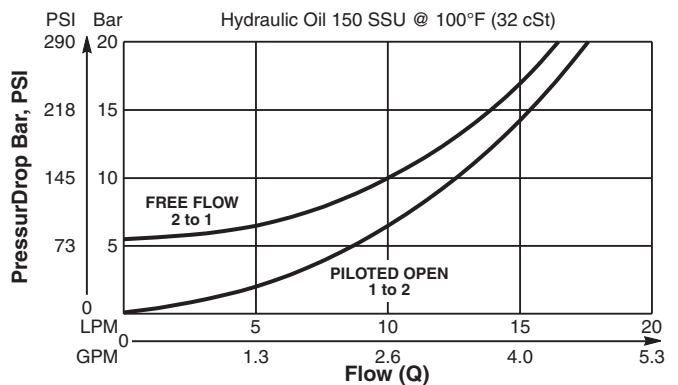

Dimensions Millimeters (Inches)

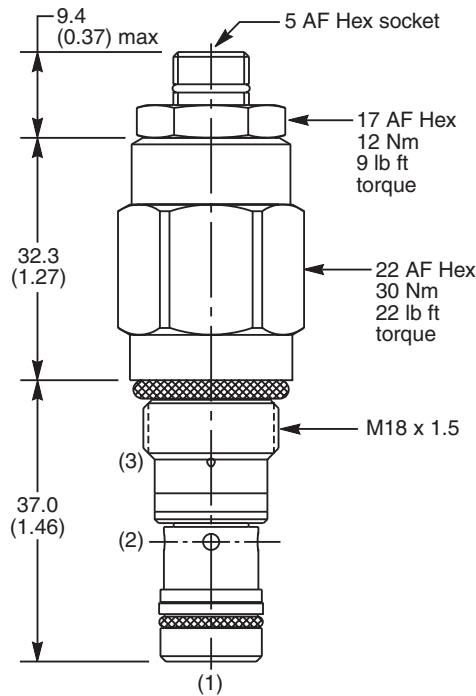

Ordering Information

E6	K	020	<input type="checkbox"/>	<input type="checkbox"/>	<input type="checkbox"/>
Load Control Valve	Pilot Ratio		Adjustment Style	Cracking Pressure	Seals

Code	Pilot Ratio
K	15 : 1

Code	Adjustment Style / Kit No.
Z	Screw Adjust (Standard)
T	Tamper Resistant (TC1125)

Code	Cracking Pressure
	Omit for no setting (Standard)* Specify setting if required

**Standard valve is set to crack at 215 Bar (3120 PSI). Valve to be set to 1.3 times maximum load induced pressure.*

Code	Seals / Kit No.
N	Nitrile, Buna-N (Std.) / (SK30087N-1)
V	Fluorocarbon / (SK30087V-1)

Order Bodies Separately

LB10	<input type="checkbox"/>	<input type="checkbox"/>
Line Body	Porting	Body Material

Code	Porting
310	3/8" BSP (main) 1/4" BSP (aux)
318	3/8" SAE (main) 1/4" SAE (aux)
312	3/8" BSP Dual Cavity
319	3/8" SAE Dual Cavity

Code	Body Material
A	Aluminum
S	Steel

- CV** Check Valves
- SH** Shuttle Valves
- LM** Load/Motor Controls
- FC** Flow Controls
- PC** Pressure Controls
- LE** Logic Elements
- DC** Directional Controls
- MV** Manual Valves
- SV** Solenoid Valves
- PV** Proportional Valves
- CE** Coils & Electronics
- BC** Bodies & Cavities
- TD** Technical Data

Technical Information

- CV** Check Valves
- SH** Shuttle Valves
- LM** Load/Motor Controls
- FC** Flow Controls
- PC** Pressure Controls
- LE** Logic Elements
- DC** Directional Controls
- MV** Manual Valves
- SV** Solenoid Valves
- PV** Proportional Valves
- CE** Coils & Electronics
- BC** Bodies & Cavities
- TD** Technical Data

General Description

Threaded Cartridge Style Counterbalance Valve. 3 Port, Independent of Back Pressure, Vented to Atmosphere. Pilot assisted, designed for motion control applications. For additional information see Technical Tips on pages LM1-LM4.

Features

- Spring chamber isolated from system back pressure by double seal, eliminating vent port leakage and need for separate drain line
- Poppet construction for minimal leakage
- Incorporates direct acting relief valve for overload protection
- Includes reverse check valve within body, saving space and minimizing installation cost
- Fully sealed pilot for high efficiency and accurate pilot ratio
- Three pilot ratios available, 1:1, 3:1 and 5:1
- Adjustable and tamper resistant versions available
- All external parts zinc plated

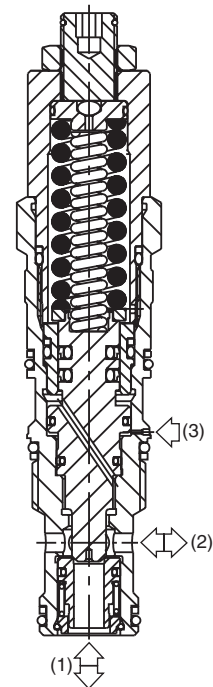
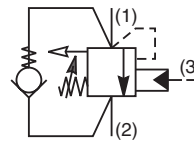
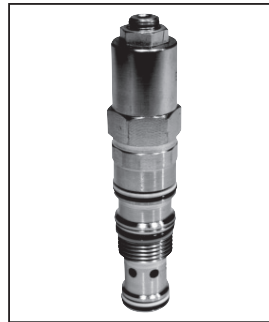

Specifications

Rated Flow	60 LPM (16 GPM)
Pressure	40 - 350 Bar (580 - 5000 PSI)
Sensitivity: Pressure/Turn	78 Bar (1131 PSI)
Pilot Ratio	E6C1 - 1 : 1 E6K1 - 3 : 1 E6P1 - 5 : 1
Cartridge Material	All parts steel. All operating parts hardened steel.
Operating Temp. Range/Seals	-40°C to +93.3°C (Nitrile) (-40°F to +200°F) -31.7°C to +121.1°C (Fluorocarbon) (-25°F to +250°F)
Fluid Compatibility/ Viscosity	Mineral-based or synthetic with lubricating properties at viscosities of 45 to 2000 SSU (6 to 420 cSt)
Filtration	ISO Code 16/13, SAE Class 4 or better
Approx. Weight	0.22 kg (0.48 lbs.)
Cavity	CAVT11A (See BC Section for more details)

Performance Curves

Relief & Pilot Performance 1 to 2

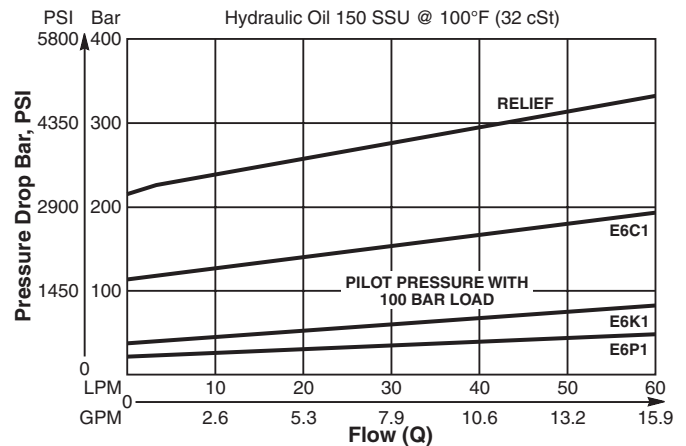

Pressure Drop vs Flow

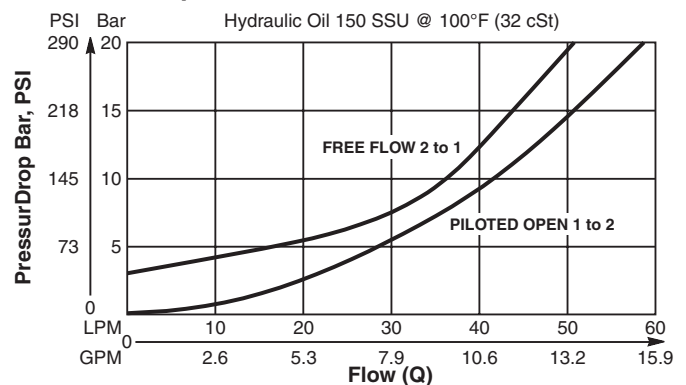

Dimensions Millimeters (Inches)

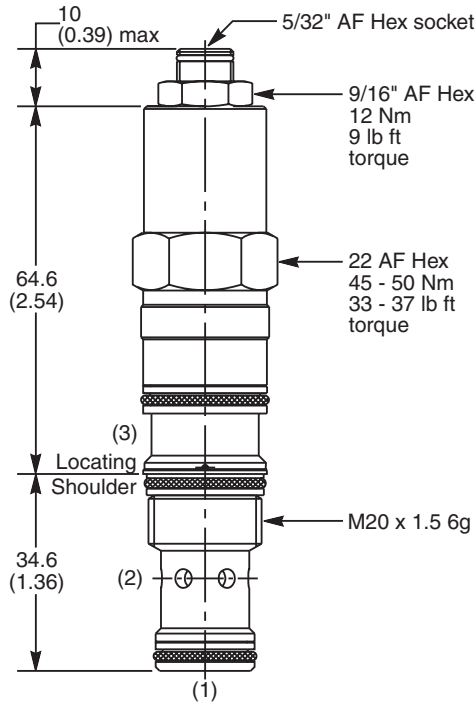

Ordering Information

E6		1			
Load Control Valve	Pilot Ratio	Adjustment Style	Cracking Pressure	Seals	

Code	Pilot Ratio
C	1 : 1
K	3 : 1
P	5 : 1

Code	Cracking Pressure
	Omit for no setting (Standard)* Specify setting if required

**Standard valve is set to crack at 215 Bar (3120 PSI). Valve to be set to 1.3 times maximum load induced pressure.*

Code	Adjustment Style / Kit No.
Z	Screw Adjust (Standard)
T	Tamper Resistant (TC1130)

Code	Seals / Kit No.
N	Nitrile, Buna-N (Std.) / (SK30700N-1)
V	Fluorocarbon / (SK30700V-1)

Order Bodies Separately

LB10		
Line Body	Porting	Body Material

Code	Porting
826	1/2" BSP (main) 1/4" BSP (aux)
825	1/2" SAE (main) 1/4" SAE (aux)
828	1/2" BSP Dual Cavity
827	1/2" SAE Dual Cavity

Code	Body Material
A	Aluminum
S	Steel

- CV** Check Valves
- SH** Shuttle Valves
- LM** Load/Motor Controls
- FC** Flow Controls
- PC** Pressure Controls
- LE** Logic Elements
- DC** Directional Controls
- MV** Manual Valves
- SV** Solenoid Valves
- PV** Proportional Valves
- CE** Coils & Electronics
- BC** Bodies & Cavities
- TD** Technical Data

Technical Information

- CV Check Valves
- SH Shuttle Valves
- LM Load/Motor Controls
- FC Flow Controls
- PC Pressure Controls
- LE Logic Elements
- DC Directional Controls
- MV Manual Valves
- SV Solenoid Valves
- PV Proportional Valves
- CE Coils & Electronics
- BC Bodies & Cavities
- TD Technical Data

General Description

Threaded Cartridge Style Counterbalance Valve. Pilot assisted, designed for motion control applications. For additional information see Technical Tips on pages LM1-LM4.

Features

- Spring chamber isolated from system backpressure by double seal, eliminating vent port leakage and need for separate drain line
- Poppet construction for minimal leakage
- Incorporates direct acting relief valve for overload protection
- Includes reverse check valve within body, saving space and minimizing installation cost
- Hardened working parts for maximum durability
- Adjustable and tamper resistant versions available
- All external parts zinc plated

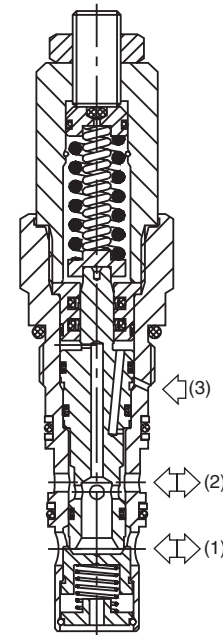
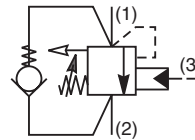
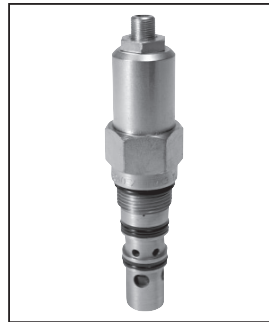

Specifications

Rated Flow	60 LPM (15.9 GPM)
Pressure	50 - 350 Bar (725 - 5000 PSI)
Sensitivity: Pressure/Turn	92 Bar (1335 PSI)
Pilot Ratio	3 : 1
Cartridge Material	All parts steel. All operating parts hardened steel.
Operating Temp. Range/Seals	-40°C to +93.3°C (Nitrile) (-40°F to +200°F) -31.7°C to +121.1°C (Fluorocarbon) (-25°F to +250°F)
Fluid Compatibility/ Viscosity	Mineral-based or synthetic with lubricating properties at viscosities of 45 to 2000 SSU (6 to 420 cSt)
Filtration	ISO Code 16/13, SAE Class 4 or better
Approx. Weight	0.33 kg (0.73 lbs.)
Cavity	68-1 (See BC Section for more details)

Performance Curves

Relief & Pilot Performance 1 to 2

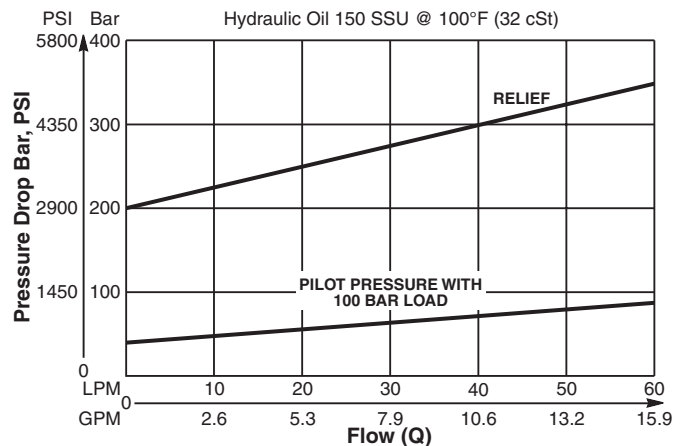

Pressure Drop vs Flow

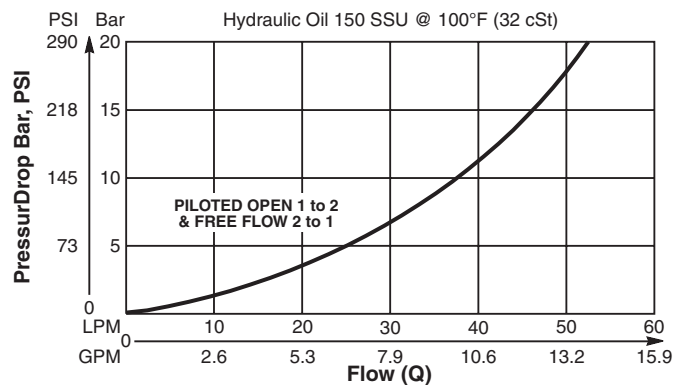

Dimensions Millimeters (Inches)

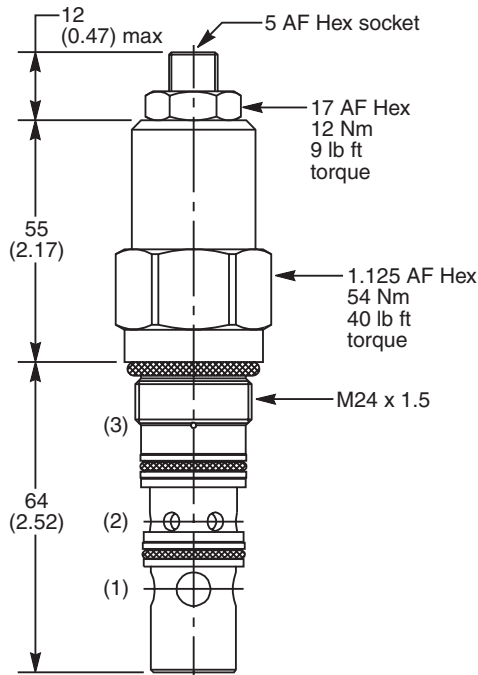

Ordering Information

E6	B	040	<input type="checkbox"/>	<input type="checkbox"/>	<input type="checkbox"/>
Load Control Valve	Pilot Ratio		Adjustment Style	Cracking Pressure	Seals

Code	Pilot Ratio
B	3 : 1

Code	Adjustment Style / Kit No.
Z	Screw Adjust (Standard)
T	Tamper Resistant (TC1125)

Code	Cracking Pressure
	Omit for no setting (Standard)* Specify setting if required

**Standard valve is set to crack at 215 Bar (3120 PSI). Valve to be set to 1.3 times maximum load induced pressure.*

Code	Seals / Kit No.
N	Nitrile, Buna-N (Std.) / (SK30059N-1)
V	Fluorocarbon / (SK30059V-1)

Order Bodies Separately

LB10	<input type="checkbox"/>	<input type="checkbox"/>
Line Body	Porting	Body Material

Code	Porting
251	1/2" BSP (main) 1/4" BSP (aux)
253	1/2" SAE (main) 1/4" SAE (aux)
259	1/2" BSP Dual Cavity
261	1/2" SAE Dual Cavity

Code	Body Material
A	Aluminum
S	Steel

- CV** Check Valves
- SH** Shuttle Valves
- LM** Load/Motor Controls
- FC** Flow Controls
- PC** Pressure Controls
- LE** Logic Elements
- DC** Directional Controls
- MV** Manual Valves
- SV** Solenoid Valves
- PV** Proportional Valves
- CE** Coils & Electronics
- BC** Bodies & Cavities
- TD** Technical Data

Technical Information

- CV Check Valves
- SH Shuttle Valves
- LM Load/Motor Controls
- FC Flow Controls
- PC Pressure Controls
- LE Logic Elements
- DC Directional Controls
- MV Manual Valves
- SV Solenoid Valves
- PV Proportional Valves
- CE Coils & Electronics
- BC Bodies & Cavities
- TD Technical Data

General Description

Threaded Cartridge Style Counterbalance Valve. Pilot assisted, designed for motion control applications. For additional information see Technical Tips on pages LM1-LM4.

Features

- High flow design with extra dampening
- Spring chamber isolated from system backpressure by double seal, eliminating vent port leakage and need for separate drain line
- Poppet construction for minimal leakage
- Incorporates direct acting relief valve for overload protection
- Includes reverse check valve within body, saving space and minimizing installation cost
- Hardened working parts for maximum durability
- Adjustable and tamper resistant versions available
- All external parts zinc plated

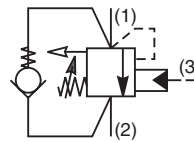
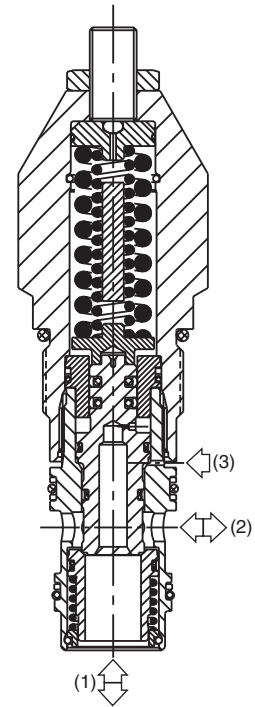
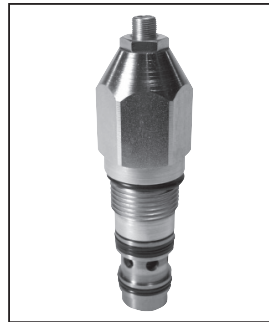

Specifications

Rated Flow	180 LPM (48 GPM)
Pressure	50 - 350 Bar (725 - 5000 PSI)
Sensitivity: Pressure/Turn	50 Bar (725 PSI)
Pilot Ratio	E6A060*409 - 8 : 1 E6B060*409 - 3 : 1
Cartridge Material	All parts steel. All operating parts hardened steel.
Operating Temp. Range/Seals	-40°C to +93.3°C (Nitrile) (-40°F to +200°F) -31.7°C to +121.1°C (Fluorocarbon) (-25°F to +250°F)
Fluid Compatibility/ Viscosity	Mineral-based or synthetic with lubricating properties at viscosities of 45 to 2000 SSU (6 to 420 cSt)
Filtration	ISO Code 16/13, SAE Class 4 or better
Approx. Weight	0.53 kg (1.17 lbs.)
Cavity	3C (See BC Section for more details)

Performance Curves

Relief & Pilot Performance 1 to 2

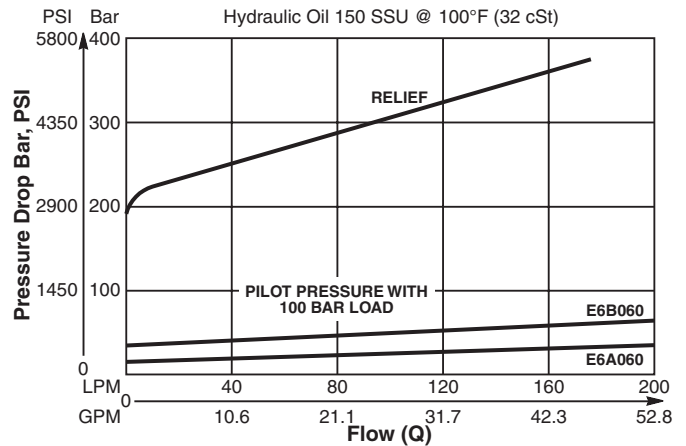

Pressure Drop vs Flow

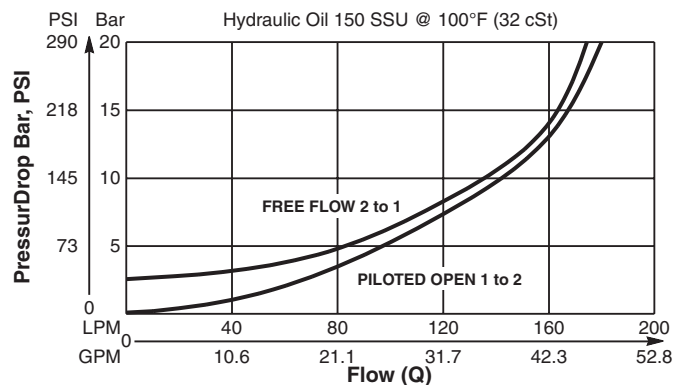

Dimensions Millimeters (Inches)

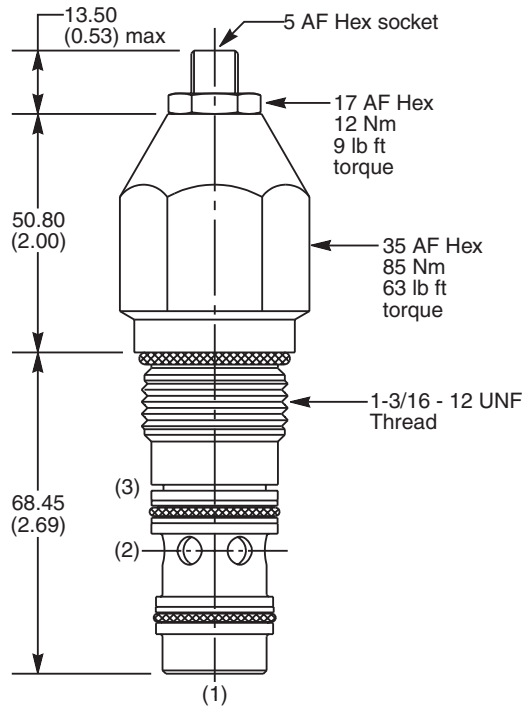

Ordering Information

E6		060				409
Load Control Valve	Pilot Ratio	Adjustment Style	Cracking Pressure	Seals	Suffix Number	

Code	Pilot Ratio
A	8 : 1
B	3 : 1

Code	Adjustment Style / Kit No.
Z	Screw Adjust (Standard)
T	Tamper Resistant (TC1125)

Code	Cracking Pressure
	Omit for no setting (Standard)* Specify setting if required

**Standard valve is set to crack at 215 Bar (3120 PSI). Valve to be set to 1.4 times maximum load induced pressure.*

Code	Seals / Kit No.
N	Nitrile, Buna-N (Std.) / (SK30008N-1)
V	Fluorocarbon / (SK30008V-1)

Code	Suffix Number
409	High flow design with extra dampening

Order Bodies Separately

LB10		
Line Body	Porting	Body Material

Code	Porting
039	3/4" BSP (main) 1/4" BSP (aux)
069	1" SAE (main) 1/4" SAE (aux)
034	3/4" BSP Dual Cavity
234	3/4" SAE Dual Cavity

Code	Body Material
A	Aluminum
S	Steel

- CV** Check Valves
- SH** Shuttle Valves
- LM** Load/Motor Controls
- FC** Flow Controls
- PC** Pressure Controls
- LE** Logic Elements
- DC** Directional Controls
- MV** Manual Valves
- SV** Solenoid Valves
- PV** Proportional Valves
- CE** Coils & Electronics
- BC** Bodies & Cavities
- TD** Technical Data

Technical Information

- CV Check Valves
- SH Shuttle Valves
- LM Load/Motor Controls
- FC Flow Controls
- PC Pressure Controls
- LE Logic Elements
- DC Directional Controls
- MV Manual Valves
- SV Solenoid Valves
- PV Proportional Valves
- CE Coils & Electronics
- BC Bodies & Cavities
- TD Technical Data

General Description

Threaded Cartridge Style Counterbalance Valve. 4 Port, Independent of Back Pressure, Vented to Drain Line. Pilot assisted, designed for motion control applications. For additional information see Technical Tips on pages LM1-LM4.

Features

- Spring chamber isolated from system back pressure by vent port and use of separate drain line
- Poppet construction for minimal leakage
- Incorporates direct acting relief valve for overload protection
- Includes reverse check valve, saving space and minimizing installation cost
- Fully sealed pilot for high efficiency and accurate pilot ratio
- Three pilot ratios available, 1:1, 3:1 and 5:1
- Adjustable and tamper resistant versions available
- All external parts zinc plated

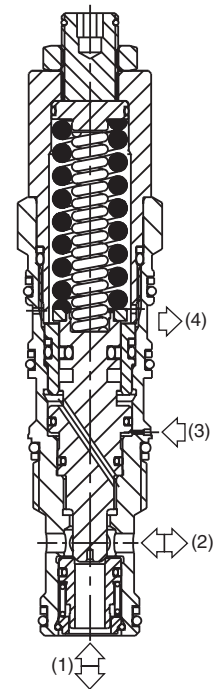
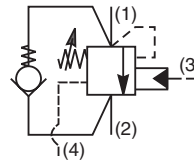

Specifications

Rated Flow	60 LPM (16 GPM)
Pressure	40 - 350 Bar (580 - 5000 PSI)
Sensitivity: Pressure/Turn	78 Bar (1131 PSI)
Pilot Ratio	E9C1 - 1 : 1 E9K1 - 3 : 1 E9P1 - 5 : 1
Cartridge Material	All parts steel. All operating parts hardened steel.
Operating Temp. Range/Seals	-40°C to +93.3°C (Nitrile) (-40°F to +200°F) -31.7°C to +121.1°C (Fluorocarbon) (-25°F to +250°F)
Fluid Compatibility/Viscosity	Mineral-based or synthetic with lubricating properties at viscosities of 45 to 2000 SSU (6 to 420 cSt)
Filtration	ISO Code 16/13, SAE Class 4 or better
Approx. Weight	0.22 kg (0.48 lbs.)
Cavity	CAVT21A (See BC Section for more details)

Performance Curves

Relief & Pilot Performance 2 to 3

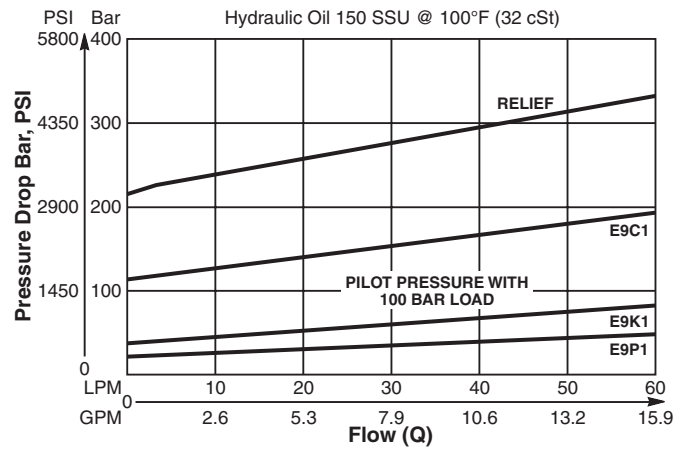

Pressure Drop vs Flow

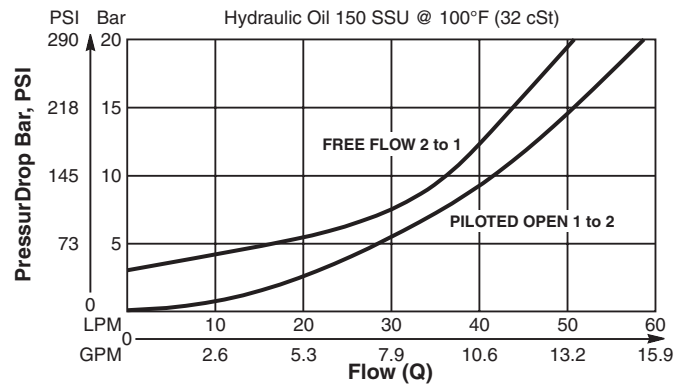

Dimensions Millimeters (Inches)

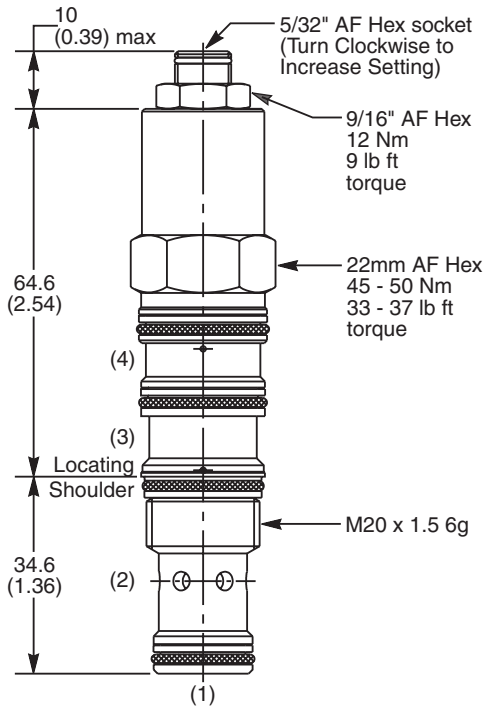

Ordering Information

E9		1			
Load Control Valve	Pilot Ratio	Adjustment Style	Cracking Pressure	Seals	

Code	Pilot Ratio
C	1 : 1
K	3 : 1
P	5 : 1

Code	Adjustment Style / Kit No.
Z	Screw Adjust (Standard)
T	Tamper Resistant (TC1130)

Code	Cracking Pressure
	Omit for no setting (Standard)* Specify setting if required

**Standard valve is set to crack at 215 Bar (3120 PSI). Valve to be set to 1.3 times maximum load induced pressure.*

Code	Seals / Kit No.
N	Nitrile, Buna-N (Std.) / (SK30701N-1)
V	Fluorocarbon / (SK30701V-1)

Order Bodies Separately

LB10		
Line Body	Porting	Body Material

Code	Porting
831	1/2" BSP (main) 3/8" BSP (pilot) 1/4" BSP (drain)
830	1/2" SAE (main) 3/8" SAE (pilot) 1/4" SAE (drain)

Code	Body Material
A	Aluminum
S	Steel