

Speicher – Zubehör accessories

Speicheradapter zu Sicherheits- und Absperrblock DI 32-2 accumulator adaptor for safety block DI 32-2 Standard – Baureihe standard range

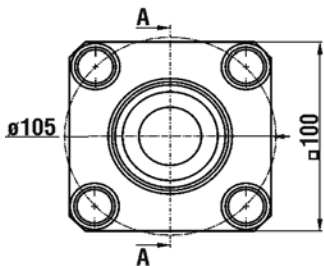

Design 1

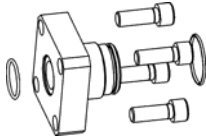
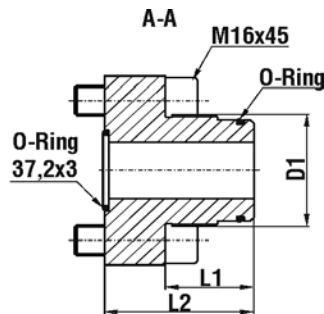

Betriebsüberdruck / MWP
 Normalstahl / NBR = 400 bar
 carbon steel / NBR = 400 bar

Material / materials
 Normalstahl / NBR
 carbon steel / NBR
 Andere Ausführungen auf Anfrage.
 Other versions on request.

Temperaturbereich / temperature range
 Normalstahl / NBR = -20 °C bis +80 °C
 carbon steel / NBR = -20 °C to +80 °C
 Andere Ausführungen auf Anfrage.
 Other versions on request.

Schrauben und O-Ringe sind Bestandteil des Lieferumfangs.
 The screws and o-rings are part of the delivery.

Die Dokumentation doc.5-100 ist zu beachten!
 Please note doc.5-100.

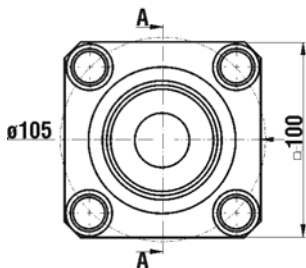
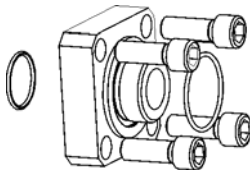

Design 2

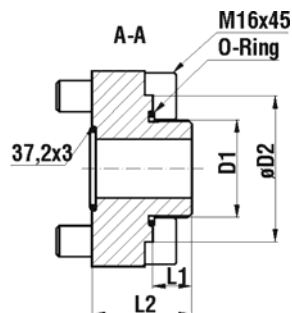

Adapter für Blasenspeicher adaptors for bladder accu							
Typ	Speicher-Typ accu type	Design	D1	øD2 (mm)	L1 (mm)	L2 (mm)	O-Ring
FS 305	IHV 0.5-1.6 L	1	G 3/4		28	58	17x3
FS 306	IHV 1-5 L		G 1"		34	64	22x3
FS 307	IHV 2.5-10 L (lg)		G 1 1/4"		37	67	30x3
FS 309	IHV 10-50 L		G 2"		44	74	48x3
FS 330		2	M30x1.5	45	15	47	32x2
FS 340			M40x1.5	60	20	51	43x3
FS 350			M50x1.5	75	20	51	53x3

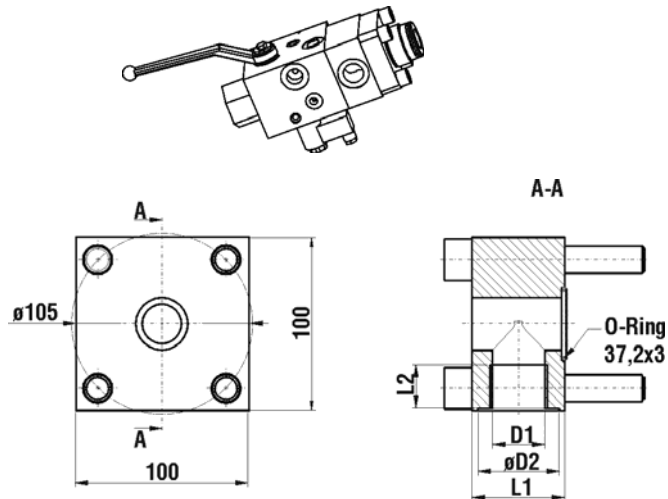
DI 32-2

Design 3

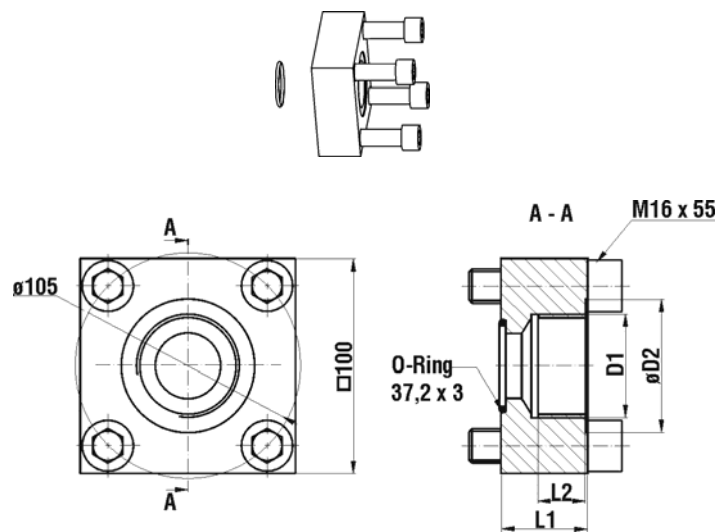

Design 4

Sonderflansche special flange							
Typ	Speicher-Typ accu type	Design	D1	ØD2 (mm)	L1 (mm)	L2 (mm)	O-Ring
FS 320		3	G1"	47	54	20	
FS 321		4	G1 ½"	65	40	22	