

Hydraulic Units UP110



motion and progress

Contents

General specifications	3
1 Power pack housings	4
2 Gear pumps	5
3 Tanks	6
4 Suction/return assembly kits for plastic tanks	8
5 Electric motors	10
6 Drives	13
7 Cartridge valves	15
8 Example of hydraulic power pack ordering code	23

General specifications

The positive experience acquired on the UP100 project, allowed us to develop a new and advanced hydraulic unit named UP110. It's specifically designed for all machine applications requiring single acting actuators. The UP110 does not replace UP100 range but it is a completion of the same.

Main features

- **Single acting circuit:**

Available as single acting circuit solenoid operated normally closed or normally open or manual operated normally closed

- **Very compact dimensions**

Two housing sides completely free (no assembled parts). Easy assembling and handling, thanks to "MF" MULTI-FUNCTION cartridge valve: Check, Unloading and Compensated flow control functions are all integrated in the MF single cartridge valve.

Easy to assemble, easy to replace

- **UP100-UP110 Interchangeability**

The interchangeability for many accessories used in UP100 version like tanks, electric motors and couplings is granted.

New components

- **Housing:**

- Pressure die casting aluminium alloy housing, completely new in its design.

- External dimensions: 133x133x40 mm (same of the UP100 power pack)

- Port: 1/4" BSP (3/8" BSP and SAE6 as available alternative)

- Fixed holes: nr.2 threaded M10x1.5x82 as per UP100 power pack

- Maximum operating pressure: 230 bar, (Peak pressure P3 = 250 bar allowed)

- Filter conveyor with inspection and cleaning easiness.

- **External gear pump AP100**

New project: pump body, balancing plate and back cover, completely new

Back cover: allows a simplified assembling using the same

suction kit for all the different horizontal tank mounting positions P01 -P02 -P03 -P04

Pump displacement range: 1.2 - 1.7 - 2.5 - 3.5 - 5 - 6.5 - 8 - 10 cc.p.r

- **Valves and cavities.**

Cavity **a** : relief valve VM01 (same type used in UP100 version)

Cavity **c** : MF - TVS = multifunction ON-OFF solenoid operated, normally closed.
MF - TOS = multifunction ON-OFF solenoid operated, normally open.

Both valves have:

- Integrated check valve function.

- Integrated flow control valve function.

Fixed flow set range: 02 - 03 - 04 - 05 - 06 - 09 - 11 -16 l/min.

- Standard voltage: 12,24, V. DC - 24, 110, 220 V. AC

- New coil 27 Watt, DIN43650, IP65

Cavity **c** : MF - TVM = multifunction manual lever control, normally closed

- Integrated check valve function.

- Integrated flow control valve function (only on customer request).

- Lever with or without electric micro switch control.

UP110 **c** cavity valve is located at the same position of the present UP100 **c** cavity.

Directives and standards

- **Atex:**

The equipment and protective systems of these catalogue ARE NOT intended for use in potentially explosive atmospheres that is to say where there is an explosive atmosphere referred to in Article 2 of the Directive 99/92/EC and referred to Article 1.3 of the Directive 94/9/EC.

- **ISO 9001: 2000**

Bucher Hydraulics S.p.A. is certified for research, development and production of directional control valves, power units, gear pumps and motors, electro pumps, cartridge valves and integrated operating blocks for hydraulic applications.

For any other UP110 specifications not introduced in this catalogue, please refer to the UP100 catalogue 200-P-991214-E

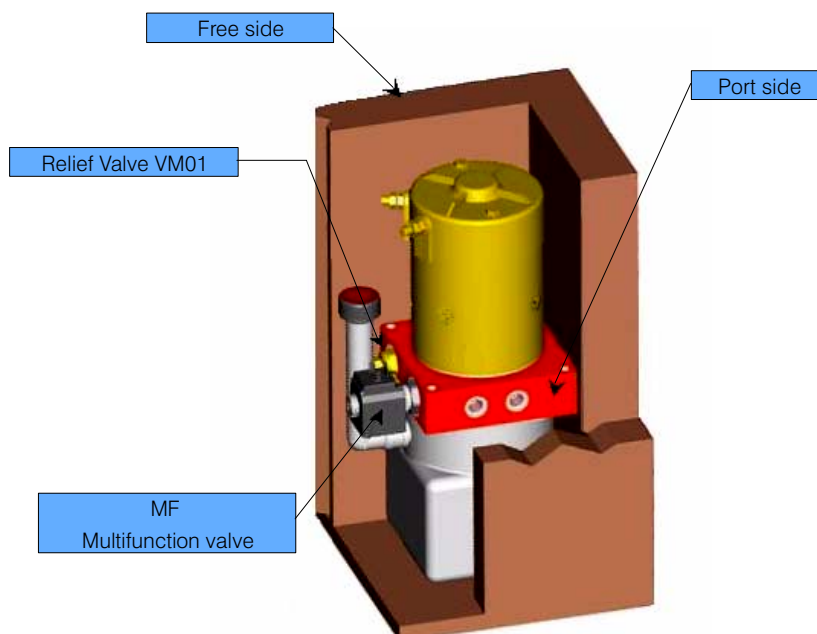

1 Power pack housings

1.1 Single acting circuit: electric control version

Cavity **a** = VM
(Relief Valve)
Cavity **c** = MF*
(Multifunction valve)

C1= hold check function
C2= flow control function
if needed
C3= unloading function

O-Ring 6425
Ø 107.32x5.34 NBR70

port M

port A

40

cavity **a**

cavity **c**

190 (7.48") (TVS version)

95.5 (3.76")

15 (.6")

117.4 (4.62")

132.5 (5.22")

M10

82 (3.23")

117.4 (4.62")

133 (5.24")

Suction port 3/8" BSP

110 (4.33")

98.3 (3.87")

30.5 (1.2")

32.5 (1.3")

6 (.24")

3 (.12")

40 (1.57")

15 (.6")

Normally open

Normally closed

A

M

P

T

P

T

T

M port is located after the C₂ flow control valve

1.2 Single acting circuit: manual control version

Cavity **a** = VM
(Relief Valve)
Cavity **c** = MF*
(Multifunction valve)

C1= check function
C2= flow control function
if needed
C3= unloading function

port M

port A

Suction port 3/8" BSP

63 (2.48")

132.5 (5.22")

82 (3.23")

30.5 (1.2")

32.5 (1.3")

Normally open

Normally closed

A

M

P

T

P

T

T

M port is located after the C₂ flow control valve

Port A	Port M	Type	Body Code
1/4" BSP	1/4" BSP	UP110K1G2-01	200.7404.3150.0
3/8" BSP	1/4" BSP	UP110K1G3-01	200.7404.3153.0
SAE6	SAE6	UP110K1S2-02	200.7404.3154.0

2 Gear pumps

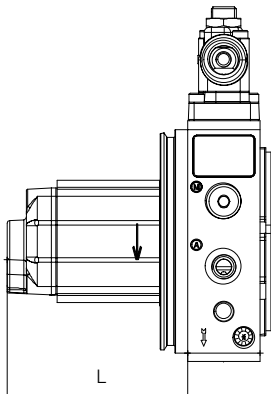

L

AP100/ - S309**

Suction port
3/8" BSP

20⁺⁵ Nm

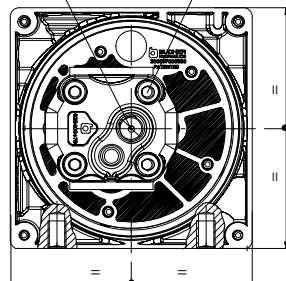

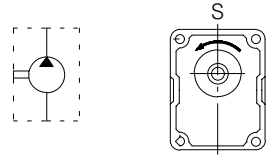

S

counterclockwise rotation

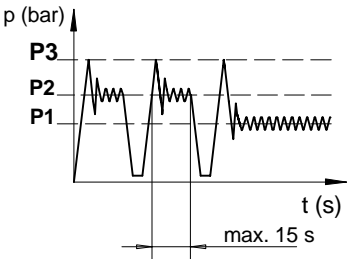

p (bar)

P3

P2

P1

t (s)

max. 15 s

Pressure levels:

P1 = continuous operating pressure

P2 = intermittent operating pressure

P3 = peak pressure

Example

	Pump	Hi-Lo	Series
2	A P 1 0 0 / 2 . 5	S	3 0 9

Displac.		AP100	Order code	L		Max. pressure						n. min.		n. max.	
cm ³ /rev	Cu.In .P.R	Pump type		mm	inch.	P1		P2		P3		P<P1	P>P1	P<P1	P>P1
						bar	PSI	bar	PSI	bar	PSI				
1.2	.073	AP100/1.2 S309	200.7482.1027.0	86.1	3.40	210	3000	230	3300	250	3600	800	1000	4500	5000
1.7	.103	AP100/1.7 S309	200.7482.2023.0	88.1	3.47	210	3000	230	3300	250	3600	650	800	4500	5000
2.5	.152	AP100/2.5 S309	200.7482.3034.0	91.4	3.60	210	3000	230	3300	250	3600	650	800	4500	5000
3.5	.213	AP100/3.5 S309	200.7482.4024.0	95.7	3.77	210	3000	230	3300	250	3600	650	800	3500	4000
4.3	.262	AP100/4.3 S309	200.7482.5016.0	99.3	3.91	210	3000	230	3300	250	3600	550	700	3500	4000
5.0	.305	AP100/5 S309	200.7482.6023.0	102.1	4.02	210	3000	230	3300	250	3600	500	650	3000	3500
6.5	.396	AP100/6.5 S309	200.7482.7026.0	107.1	4.22	190	2700	220	3150	240	3400	500	650	2500	3000
7.8	.476	AP100/8 S309	200.7482.8013.0	112.7	4.44	180	2600	210	3000	230	3300	500	650	2500	3000
10	.610	AP100/10 S309	200.7482.9080.0	121.8	4.79	150	2150	180	2600	200	2900	500	650	2000	2500

N.B. HI-Lo gear pump versions available in different displacement combinations on demand . For availability please contact our Sales Department

3.3 Round plastic tanks from 6 to 14 litres capacity

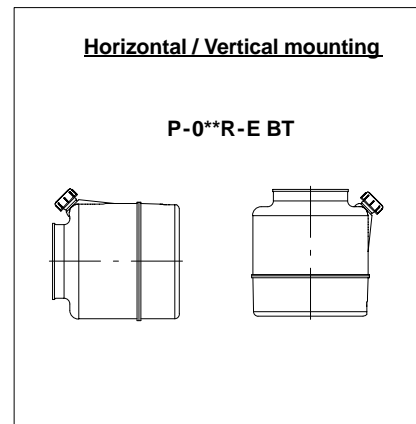
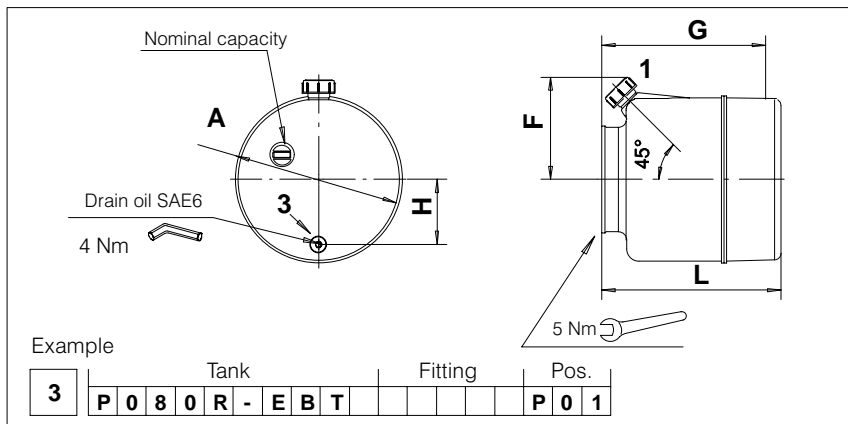

Nom. Cap.	Type	Code	A		L		F		G		H	
			mm	inch.	mm	inch.	mm	inch.	mm	inch.	mm	inch.
6 l	P-060R-E BT	200.9734.9029.0	200	7.1	220	8.7	127	5	201	8.0	80	3.2
8 l	P-080R-E BT	200.9734.5010.0	200	7.1	285	11.3	127	5	266	10.5	80	3.2
10 l	P-100R-E BT	200.9734.6010.0	200	7.1	325	12.8	127	5	306	12.1	80	3.2
12 l	P-120R-E BT	200.9734.9030.0	200	7.1	410	16.2	127	5	391	15.4	80	3.2
14 l	P-140R-E BT	200.9734.9018.0	200	7.1	490	19.3	127	5	471	18.6	80	3.2

3.4 Tank assembling position

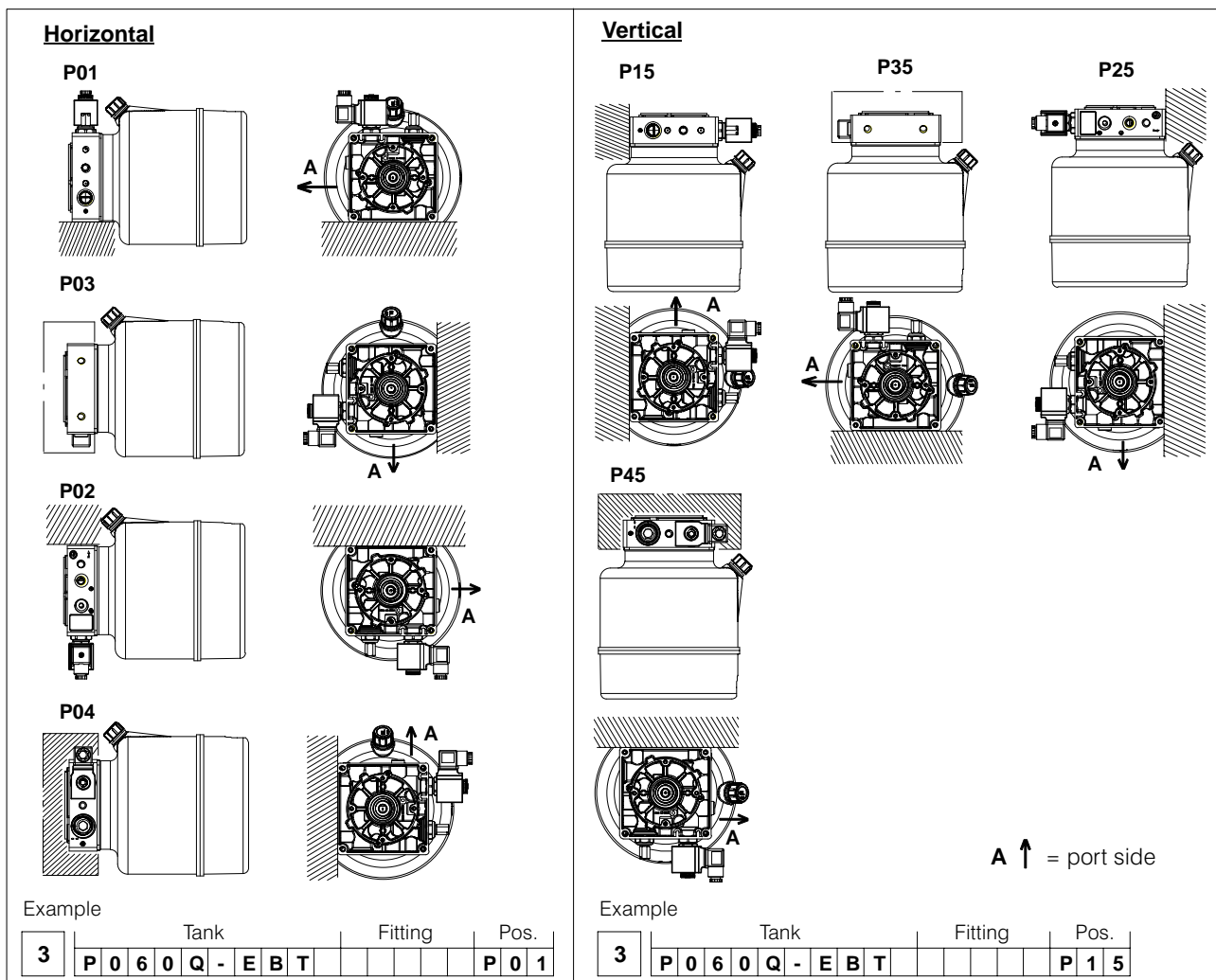

3.5 Tank fixing kits

Fixing kit for plastic tank up to 2.5 litres capacity, Code 200.7719.0015.0

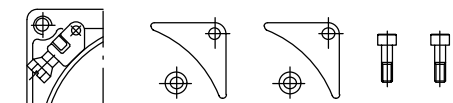

- 200.5441.16021 Tank fixing clip
- 200.6774.0040.0 Tank fixing bracket (q.ty 2)
- 200.6711.0010.1 Bracket spacer (q.ty 2)
- 200.5212.03007 M6X18 fixing bolt (q.ty 2)

Fixing kit for plastic tanks 3.5 litres capacity, Code 200.7719.0016.0

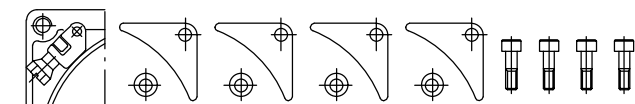

- 200.5441.16021 Tank fixing clip
 - 200.6774.0040.0 Tank fixing bracket (q.ty 2)
 - 200.6711.0010.1 Bracket spacer (q.ty 2)
 - 200.5212.03007 M6X18 fixing bolt (q.ty 2)
- To assemble the vertical tanks do not use the tank fixing clip code 200.5441.1602.1

Fixing kit for vertical tanks from 6 to 14 litres capacity, Code 200.7719.0028.0

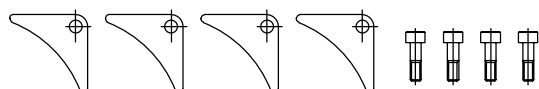

- 200.6774.0040.0 Tank fixing bracket (q.ty 4)
- 200.5212.03007 M6X18 fixing bolt (q.ty 4)

Fixing kit for horizontal tanks from 6 to 14 litres capacity, Code 200.7719.0031.0

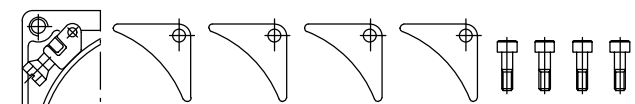

- 200.5441.16021 Tank fixing clip
- 200.6774.0040.0 Tank fixing bracket (q.ty 4)
- 200.5212.03007 M6X18 fixing bolt (q.ty 4)

Horizontal assembling for power pack with plastic/metal tanks

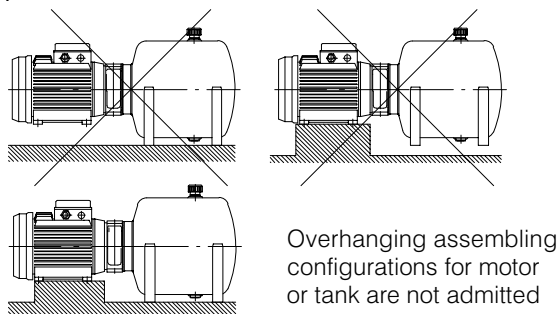

Vertical assembling for power pack with plastic/metal tanks

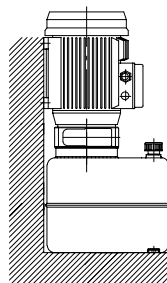

For hydraulic units assembling electric motors equal or higher than 1.5 HP- 1.1KW, it's recommended to order the B34 frame size version. Consequently it is recommended to fix the hydraulic unit by the electric motor feet or when possible both electric motor and tank feet.

4 Suction/return assembly kits for plastic tanks

4.1 Suction assembly kits for square tanks from 1.5 to 3.5 litres

Pump S309	Horizontal positions - P01, P02, P03, P04			
	P-015Q-*	P-016Q-*	P-025Q-*	P-035Q-*
AP100/1.2	200.7599.0106.0	200.7599.0106.0	200.7599.0107.0	200.7599.0107.0
AP100/1.7				
AP100/2.5				
AP100/3.5				
AP100/4.3				
AP100/5				
AP100/6.5				
AP100/8				
AP100/10				

Pump S309	Vertical positions - P15, P35, P25, P45			
	P-015Q-*	P-016Q-*	P-025Q-*	P-035Q-*
AP100/1.2	200.7599.0074.0	200.7599.0065.0	200.7599.0077.0	200.7599.0073.0
AP100/1.7	200.7599.0074.0	200.7599.0075.0	200.7599.0077.0	200.7599.0073.0
AP100/2.5	200.7599.0074.0	200.7599.0075.0	200.7599.0077.0	200.7599.0073.0
AP100/3.5		200.7599.0066.0	200.7599.0081.0	200.7599.0073.0
AP100/4.3		200.7599.0066.0	200.7599.0022.0	200.7599.0072.0
AP100/5		200.7599.0074.0	200.7599.0022.0	200.7599.0072.0
AP100/6.5			200.7599.0022.0	200.7599.0072.0
AP100/8			200.7599.0130.0	200.7599.0099.0
AP100/10			200.7599.0105.0	200.7599.0099.0

4.2 Suction assembly kits for square tanks from 6 to 12 litres

Pump S309	Horizontal positions - P01, P02, P03, P04			
	P-060Q-*	P-080Q-*	P-100Q-*	P-120Q-*
AP100/1.2 - 1.7 - 2.5 - 3.5 - 4.3 - 5 - 6.5 - 8 - 10	200.7599.0107.0			

Pump S309	Vertical positions - P15, P35, P25, P45			
	P-060Q-*	P-080Q-*	P-100Q-*	P-120Q-*
AP100/1.2	200.7599.0082.0	200.7599.0155.0	200.7599.0147.0	200.7599.0146.0
AP100/1.7	200.7599.0082.0	200.7599.0155.0	200.7599.0147.0	200.7599.0146.0
AP100/2.5	200.7599.0148.0	200.7599.0155.0	200.7599.0147.0	200.7599.0146.0
AP100/3.5	200.7599.0148.0	200.7599.0155.0	200.7599.0147.0	200.7599.0146.0
AP100/4.3	200.7599.0148.0	200.7599.0135.0	200.7599.0154.0	200.7599.0149.0
AP100/5	200.7599.0073.0	200.7599.0135.0	200.7599.0154.0	200.7599.0149.0
AP100/6.5	200.7599.0073.0	200.7599.0153.0	200.7599.0154.0	200.7599.0149.0
AP100/8	200.7599.0151.0	200.7599.0153.0	200.7599.0154.0	200.7599.0149.0
AP100/10	200.7599.0067.0	200.7599.0083.0	200.7599.0143.0	200.7599.0150.0

4.3 Suction assembly kits for round tanks from 6 to 14 litres

Pump S309	Horizontal positions - P01, P02, P03, P04				
	P-060R-*	P-080R-*	P-100R-*	P-120R-*	P-140R-*
AP100/1.2 - 1.7 - 2.5 - 3.5 - 4.3 - 5 - 6.5 - 8 - 10	200.7599.0115.0				

Pump S309	Vertical positions - P15, P35, P25, P45				
	P-060R-*	P-080R-*	P-100R-*	P-120R-*	P-140R-*
AP100/1.2	200.7599.0022.0	200.7599.0151.0	200.7599.0083.0	200.7599.0146.0	200.7599.0146.0
AP100/1.7	200.7599.0022.0	200.7599.0151.0	200.7599.0083.0	200.7599.0146.0	200.7599.0146.0
AP100/2.5	200.7599.0022.0	200.7599.0072.0	200.7599.0068.0	200.7599.0146.0	200.7599.0146.0
AP100/3.5	200.7599.0130.0	200.7599.0072.0	200.7599.0068.0	200.7599.0146.0	200.7599.0146.0
AP100/4.3	200.7599.0130.0	200.7599.0067.0	200.7599.0082.0	200.7599.0149.0	200.7599.0149.0
AP100/5	200.7599.0084.0	200.7599.0067.0	200.7599.0082.0	200.7599.0149.0	200.7599.0149.0
AP100/6.5	200.7599.0084.0	200.7599.0085.0	200.7599.0148.0	200.7599.0149.0	200.7599.0149.0
AP100/8	200.7599.0078.0	200.7599.0085.0	200.7599.0073.0	200.7599.0149.0	200.7599.0149.0
AP100/10	200.7599.0112.0	200.7599.0077.0	200.7599.0073.0	200.7599.0150.0	200.7599.0150.0

24 V - 2200 W

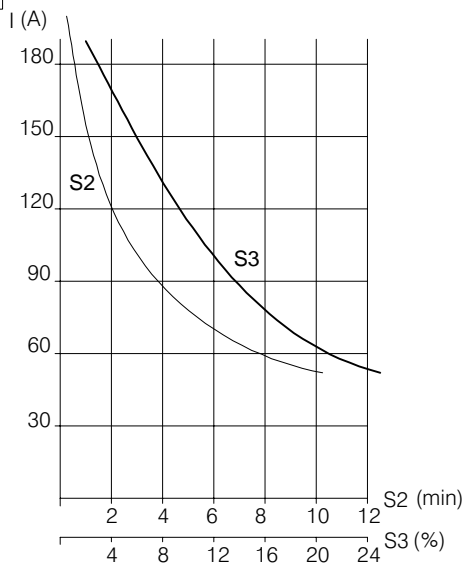
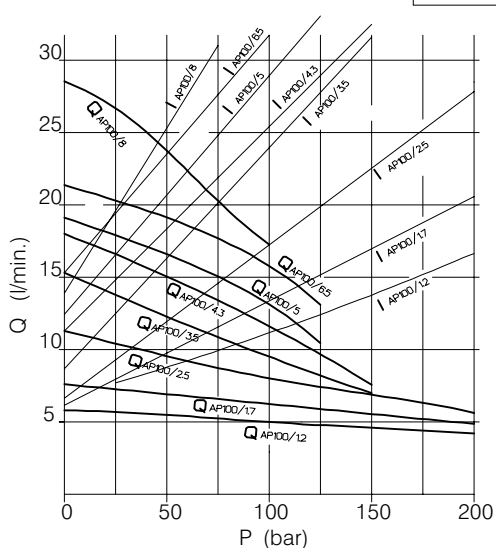

Voltage: **24 V**
 Nominal power: **3000 W**
 Protection index: **IP44**

Insulation class: **F**
 Brushes kit: **200.5441.38011**

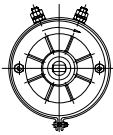
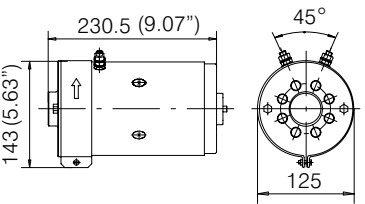
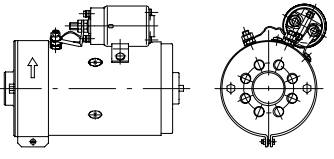
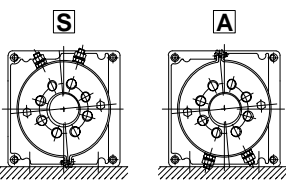
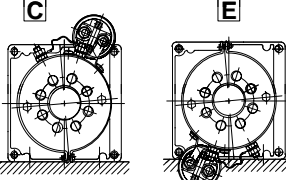
	Motor	Motor with relay	
 Clockwise Rotation			Motor mounting standard position 
Type	T106K	C248AK/C0 +R210	Relay mounting standard position 
Code	200.5439.24806	200.7633.2006.0	
Relay		Heavy duty	
Relay type		R210 200.5441.3421.0	
		Standard positions C-E only	

24 V - 3000 W

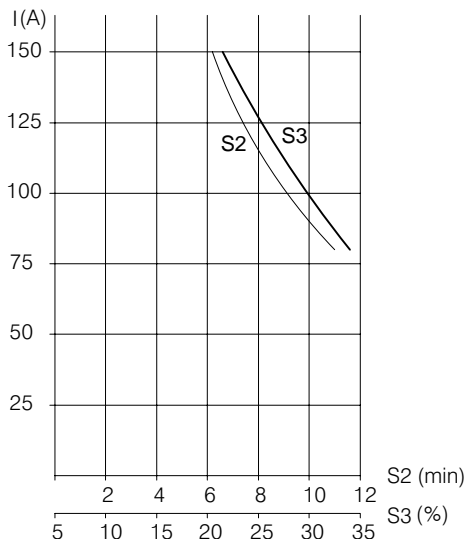
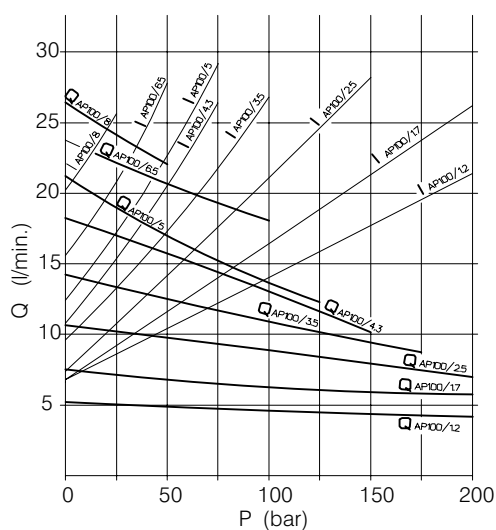

5.2 A.C. Electric motors

Frame size B14 SINGLE PHASE motor				
Power		Size	Type	Code
kW	HP			
0.25	0.33	71	T209	200.5431.61221
0.37	0.5	71	T201	200.5431.61823
0.55	0.75	80	T202	200.5431.62231
0.75	1	80	T203	200.5431.62631
1.1	1.5	90	T204	200.5431.63041
1.5	2	90	T205	200.5431.63441
2.2	3	100	T206	200.5431.64051

Frame size B34 SINGLE PHASE motor				
Power		Size	Type	Code
kW	HP			
0.25	0.33	71	T709	200.5431.61223
0.37	0.5	71	T701	200.5431.61822
0.55	0.75	80	T702	200.5431.62233
0.75	1	80	T703	200.5431.62633
1.1	1.5	90	T704	200.5431.63042
1.5	2	90	T705	200.5431.63442
2.2	3	100	T706	200.5431.64052

Frame size B14 THREE PHASE motor				
Power		Size	Type	Code
kW	HP			
0.25	0.33	71	T009	200.5435.61221
0.37	0.5	71	T001	200.5435.61821
0.55	0.75	80	T002	200.5435.62231
0.75	1	80	T003	200.5435.62631
1.1	1.5	90	T004	200.5435.63041
1.5	2	90	T005	200.5435.63441
2.2	3	100	T006	200.5435.64051
3	4	100	T007	200.5435.64851
4	5.5	100	T008	200.5435.65061

Frame size B34 THREE PHASE motor				
Power		Size	Type	Code
kW	HP			
0.25	0.33	71	T509	200.5435.61222
0.37	0.5	71	T501	200.5435.61822
0.55	0.75	80	T502	200.5435.62232
0.75	1	80	T503	200.5435.62632
1.1	1.5	90	T504	200.5435.63042
1.5	2	90	T505	200.5435.63442
2.2	3	100	T506	200.5435.64052
3	4	100	T507	200.5435.64852
4	5.5	100	T508	200.5435.65062

Mounting position

Standard position

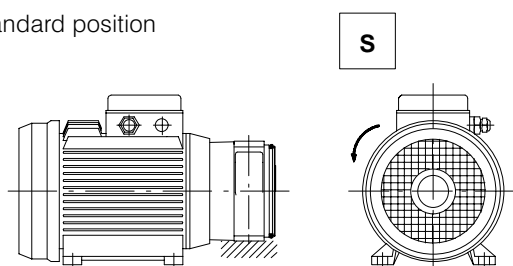

Left lateral

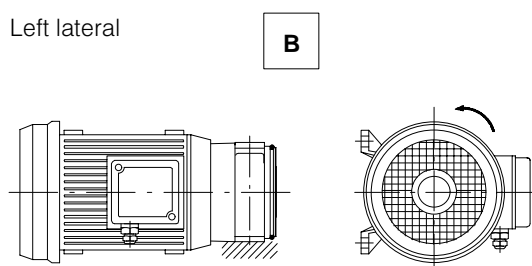

Reversal position

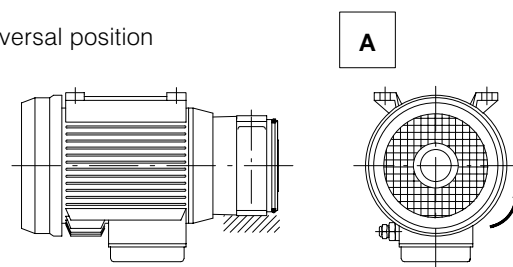

Right lateral

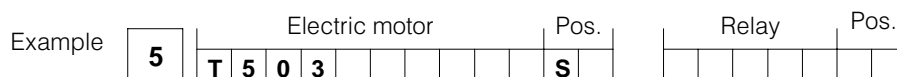
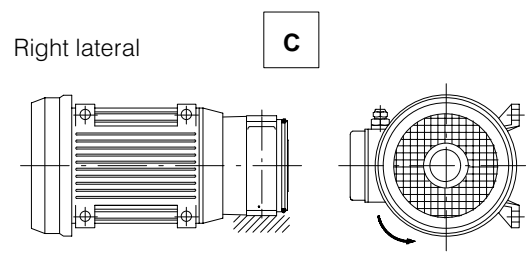

N.B.: Looking at the fan side the e. motor must rotate counterclockwise

6 Drives

The tables allow selection to select the correct drive in function of the selected motor.

6.1 Drives for D.C. motor

Motor type			Voltage	Power	Type
C135AK/X0	C135AK/X0 + R104	C135AK/X0 + R107	12 V	1600 W	E145
C240AK/Y0	C240AK/Y0 + R203	C240AK/Y0 + R210	24 V	2200 W	
T106K		C248AK/C0 + R210	24 V	3000 W	E156

6.2 Drives for A.C. motor

6.2.1 Single phase

Motor type	Power		Type
	KW	HP	
T209-T709	0.25	0.33	E133
T201-T701	0.37	0.5	
T202-T702	0.55	0.75	E131
T203-T703	0.75	1	
T204-T704	1.1	1.5	E132
T205-T705	1.5	2	
T206-T706	2.2	3	E137

6.2.2 Three phase

Motor type	Power		Type
	KW	HP	
T009-T509	0.25	0.33	E133
T001-T501	0.37	0.5	
T002-T502	0.55	0.75	E131
T003-T503	0.75	1	
T004-T504	1.1	1.5	E132
T005-T505	1.5	2	
T006-T506	2.2	3	E137
T007-T507	3	4	
T008-T508	4	5.5	

6.3 Drive E145 code 200.9604.0040.0

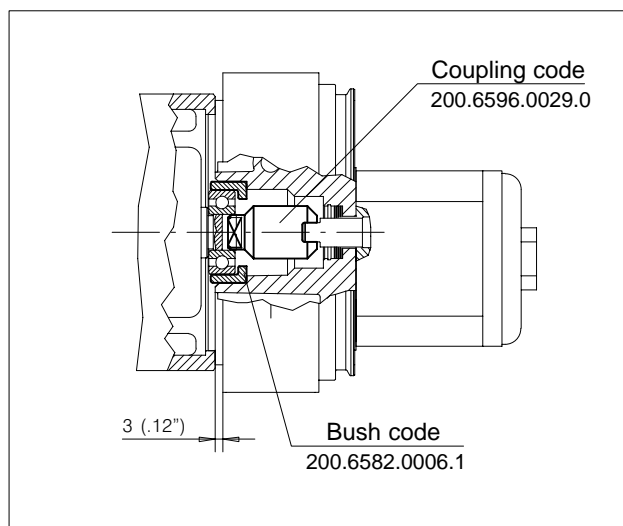

6.4 Drive E156 code 200.6596.0028.0

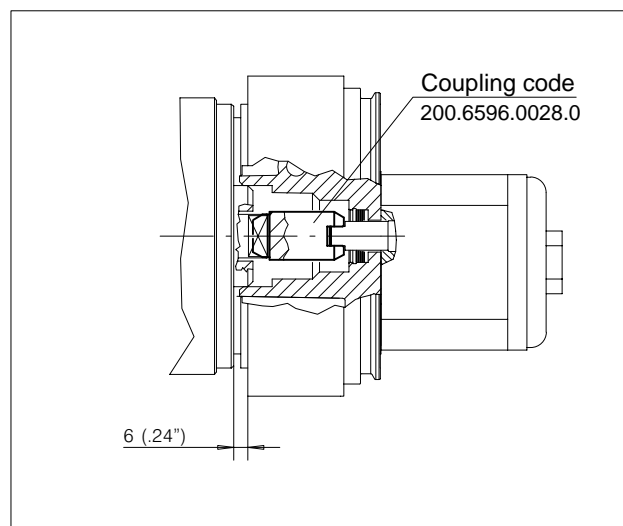

6.5 Drive E131 code 200.9604.0043.0

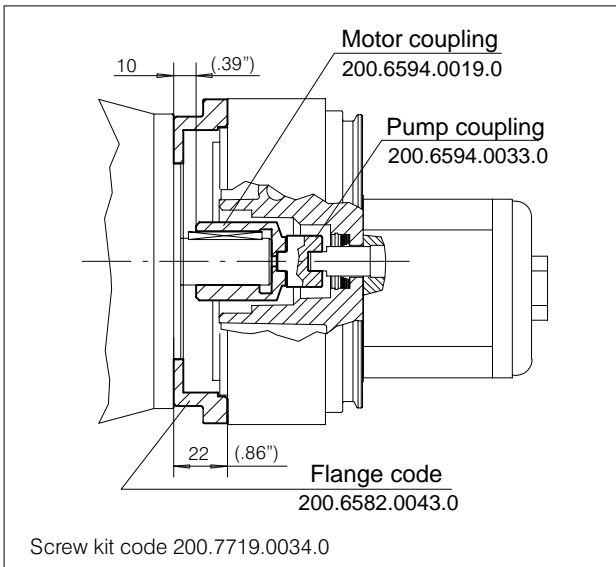

6.6 Drive E132 code 200.9604.0044.0

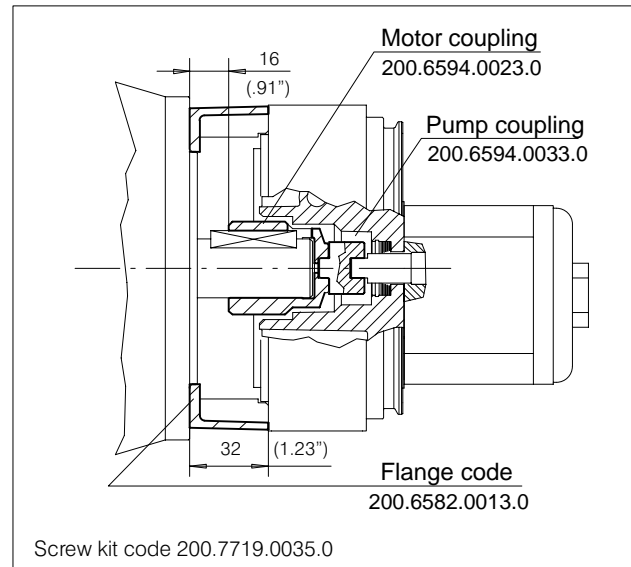

6.7 Drive E133 code 200.9604.0042.0

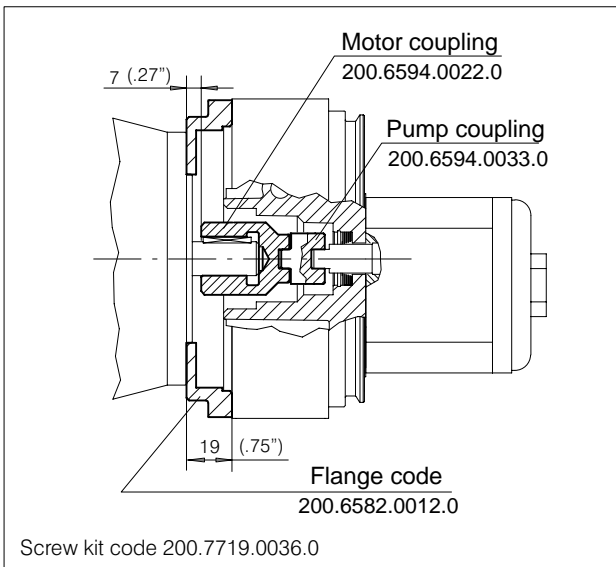

6.8 Drive E137 code 200.9604.0045.0

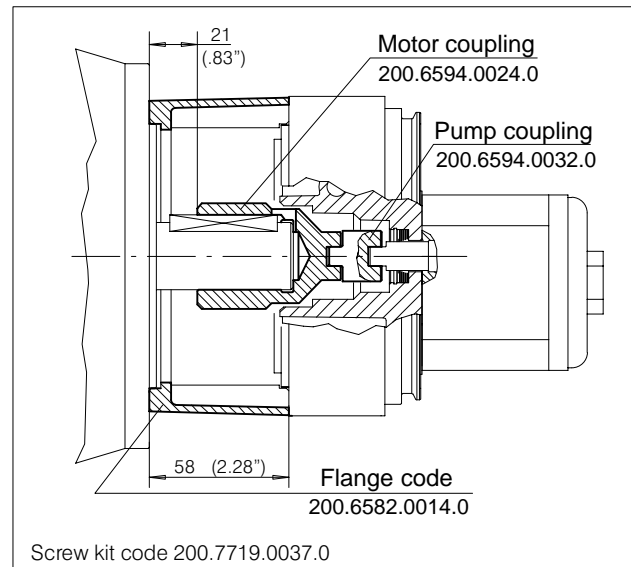

7 Cartridge valves

7.1 General information

This chapter includes all technical information relating to valves for use in conjunction with the housings described in the section 1.

Complete the designation codes for the selected valve according to the technical information and guidelines given for each component.

7.1.1 Materials

Bucher Hydraulics cartridge valves are manufactured using steel of high mechanical strength. Friction and potential wear are minimized by special heat treatments. Surface heat treatments protect parts exposed to the external environment. Standard seals are Buna N, with backup ring in PTFE. For application requiring special compound (Viton, etc.) consult our Sales Dept..

7.1.2 Indication for use

Use mineral oil based hydraulic fluids to ISO/DIN standard, only. Recommended viscosity range: 20-120 mm²/s (cSt) maximum viscosity 700 mm²/s (cSt).

For different fluids and operating conditions, consult our Sales Dept..

All valves showed in the present catalogue are marked with correct flow direction, please observe it always. Valves must never be tampered with or modified. Any unwarranted interference may adversely affect the safety and correct operation of the entire system. Seals and backup rings are user-serviceable. The appropriate replacement kit is indicated for each valve. Before installing a valve in its cavity, ensure that the housing and all components of the system are clean. Smear external seals lightly with grease, and check that any filters installed are correctly positioned.

Tighten the valve to the specified torque setting.

7.1.3 General technical information

All valves with leakage-free operating characteristics are 100% factory tested.

Nonetheless, the guaranteed maximum leakage may be exceeded if the valve is installed in a system with inadequate filtration.

In the case of valves subject to adjustable setting, such as the pressure relief and if not specified in the order, we set them according standard setting values indicated at page 16/24.

7.1.4 Solenoid valves.

The correct selection of the solenoid valve is related to the maximum flow rate and operating pressure values. In a system with a single acting cylinder, therefore, it must be considered that the effective rate of flow through the unloading solenoid valve is not the flow delivered by the pump, but rather the momentary flow exhausted from the cylinder, or the restricted flow needing a pressure-compensated flow control valve, if installed.

The nominal voltage is the value indicated on the solenoid. Effective voltage must be measured at the terminals of the solenoid connector. A maximum allowed tolerance of $\pm 10\%$ in relation to the nominal value is accepted.

Incorrectly power supply components and cables (which length has to be as shorter as possible) and/or low battery charge can cause not correct solenoid valve operation.

All solenoids indicated are designed for d.c. operation. Operation with a.c. supply requires the use of a special connector incorporating a bridge rectifier. When energized with a.c. voltage, the solenoids can operate at 50 or 60 Hz frequency, without distinction.

The connection used for standard solenoids are to DIN 43650. Solenoid with different connections (Kostal, direct wiring, etc.) can be supplied on request, after agreement with our Sales Dept..

The solenoid can be rotated through 360°, and the connector positioned at 90° intervals.

Specified performance data was recorded in stabilized solenoid operated temperature and voltage at the -10% of the nominal value.

All solenoid valves are fitted with protective O-rings installed between the tube and the solenoid.

This protects internal parts from condensation and contaminants, which could cause malfunction.

Standard solenoids are not suitable for operation in environments where there is any risk of explosion (see page 3)

7.1.5 General notes and d.c. power input

A swift and secure coupling is obtained using the special connector (type 200.544110009).

The cable coming from the d.c. power source (batteries, rectified a.c. main supply, etc.) must be connected as indicated in the diagram.

The negative and positive polarity of the wire need not be verified for connection purposes. The connector incorporates a terminal for earthing the solenoid.

It is important to check that the grommet and armour clamp nut are correctly assembled, as this prevents the cable being wrenched from connector.

7.1.6 General notes on a.c. power input

Solenoid valves can be operated off the a.c. mains supply using a special connector (type 200.544110012) which converts the current to provide the d.c. input required by the solenoid.

The connector in question is identified by a symbol marked both on the top and on the bottom face.

The conversion from alternate to direct current is effected by a rectifier circuit comprising a four-diode bridge, and a voltage-dependent resistor protecting against over voltages in the power supply circuit.

Accordingly, the solenoid are designed to operate correctly only when connected to a diode bridge which reduces the input voltage by 10%.

The earth connection is made by way of the terminal provided.

For users wishing to make up special circuits and blocks with Bucher Hydraulics S.p.A. cartridge valves, it is important to observe the indications given below when machining the cavities.

7.2 Pressure relief valve

Direct acting
Equilibrated piston
Adjustable setting
4 setting pressure range

Max. pressure. 300 bar
Max flow rate 40 l/min
Temperature range -20/+90 °C
Weight 0.120 Kg

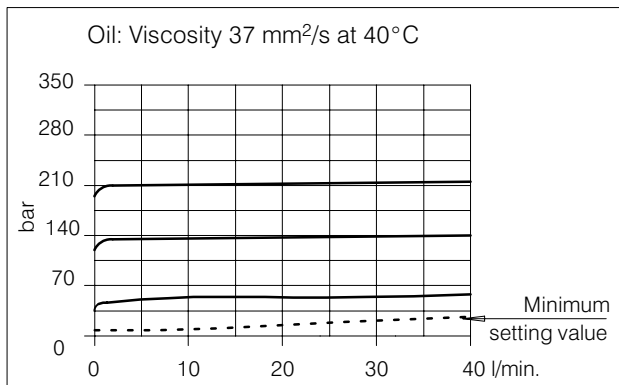
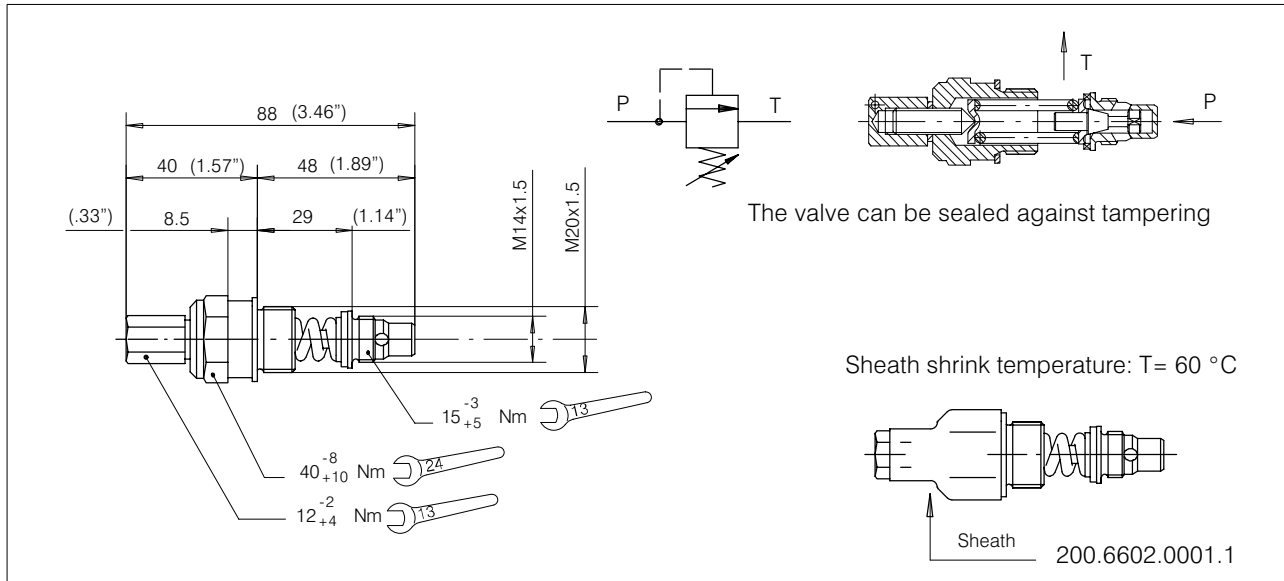

N.B.: A wrench with the appropriate hex. profile is required to secure the valve in its cavity.

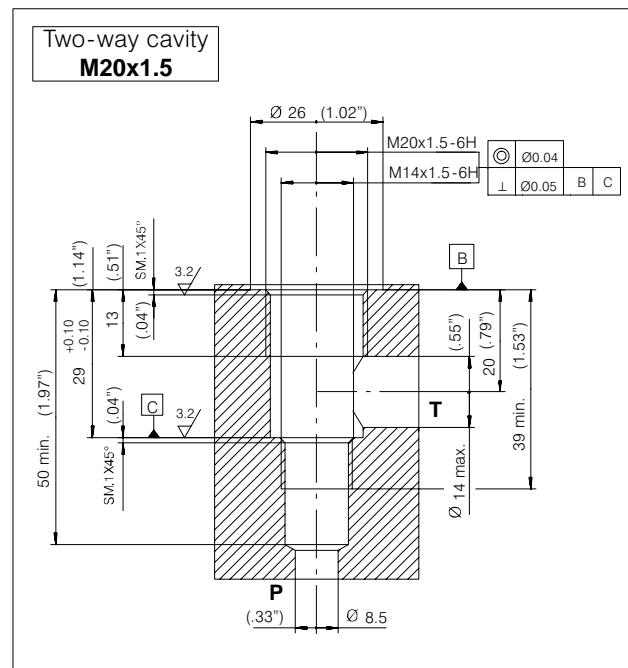

A heat-shrinkable sheath can be supplied, if requested to prevent the valve being tampered with. When ordering, state in full the sheath part number, and, if the valve is to be supplied with sheath already fitted, the relief pressure setting required. Maximum permissible pressure value: 230 bar

Pressure setting

For present values other than those indicated, replace the first two digits of the designation with the setting required. For example, required setting 120 bar: designation type 12 VM01. Always check that the required value falls within the standard ranges of adjustment.

Spring	Spring color	Spring code	Setting range	Standard setting	Type	Code
00			Plugged	Without valve	00VC00	200.9784.0014.0
02		200.6624.0147.0	5 - 30 bar	20 bar	02VM01	200.9874.0070.0
06	Yellow	200.6624.0145.0	30 - 95 bar	60 bar	06VM01	200.9874.0072.0
15	Green	200.6624.0148.0	95 - 210 bar	150 bar	15VM01	200.9874.0074.0
22	Blue	200.6624.0146.0	200 - 300 bar	220 bar	22VM01	200.9874.0071.0

7.3 Solenoid operated directional valve: MF** (multifunction valve) - Normally closed

Normally closed
Poppet type
Direct acting

Flow from P to A (solenoid not energized)
Flow from A to T (el. motor must be OFF)

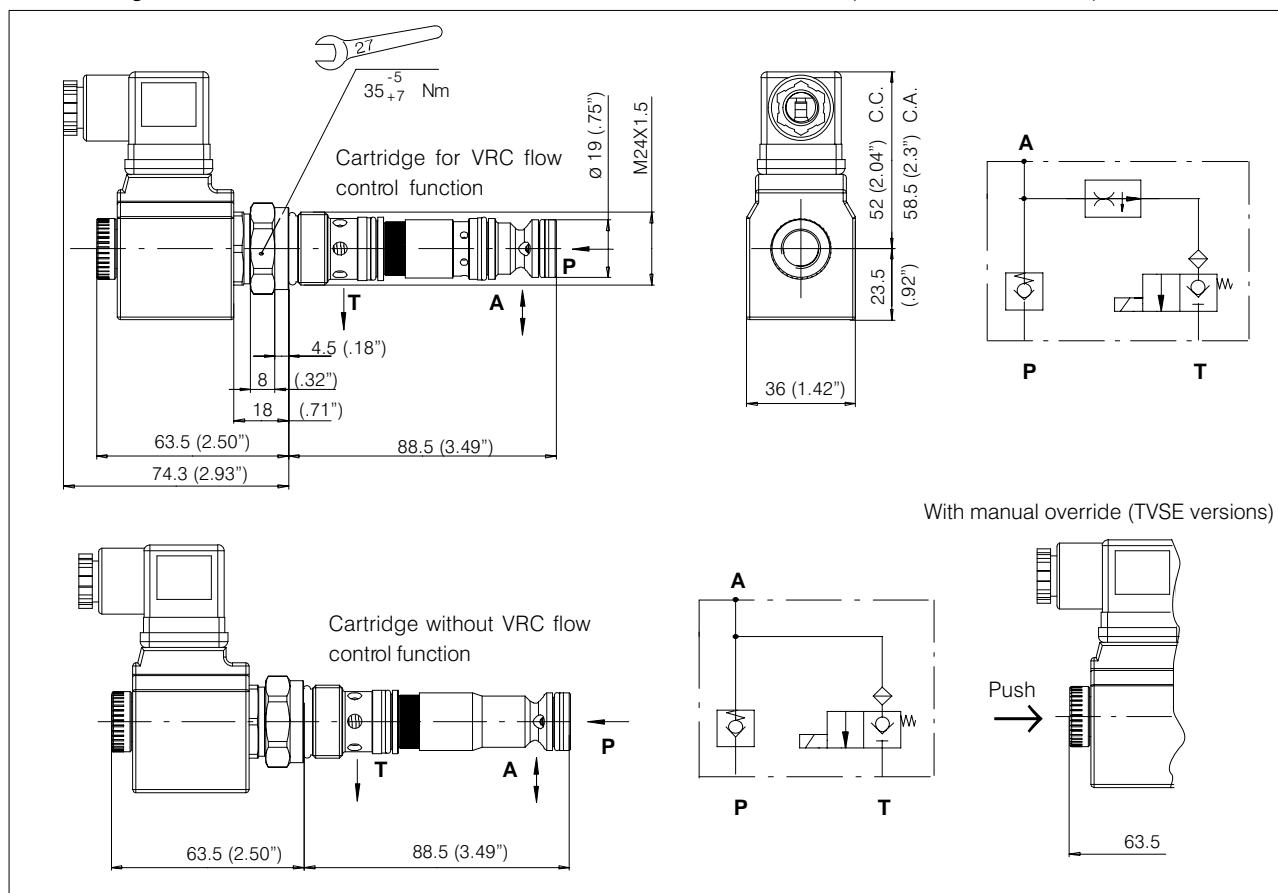

Electric performances	
Max. pressure	230 bar
Max recommended pressure	210 bar
Max. flow (see the diagrams)	14 l/min. 210 bar
Rated power	27 Watt
Duty	ED= 100%

Internal leakage	0-5 drops/min.	
Temperature range	-20/+90° C	
Opening time (50-210 bar)	15-80 ms.	
Closing time (50-210 bar)	10-60 ms.	
O-Ring kit code	with VRC	200.7742.0037.0
	without VRC	200.7742.0036.0

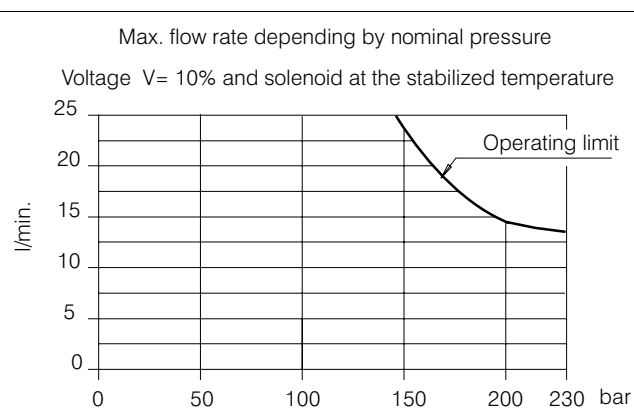
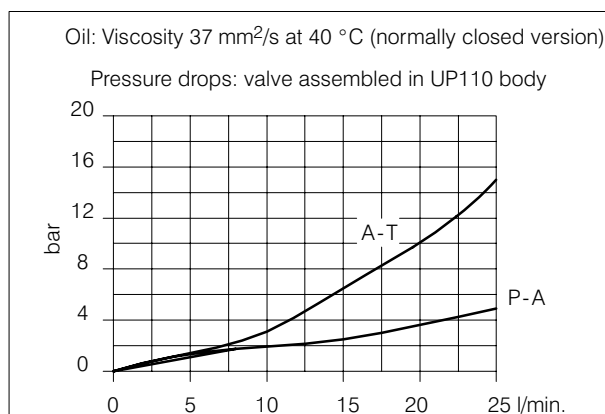

Electrical version	VAL MF	-	TVS	/	09FC	-	23	-	HC
Multifunction valve	MF								
Normally closed	TVS								
Normally closed with manual override	TVSE								
								Connector type DIN 43650	HC
Flow control function Tolerance: ± 15 %	Type							Voltage Tolerance: ± 10 %	Type
2 l/min	02FC							12 VDC	13
3 l/min	03FC							24 VDC	23
4 l/min	04FC							24 VAC	21
5 l/min	05FC							110 VAC	41
6 l/min	06FC							220 VAC	51
9 l/min	09FC							Mechanical part only (without coil and connector)	P.M.
11 l/min	11FC								
12 l/min	12FC								
16 l/min	16FC								
Without flow control function	00FC								

7.4 Solenoid operated directional valve: MF** Normally open, poppet type

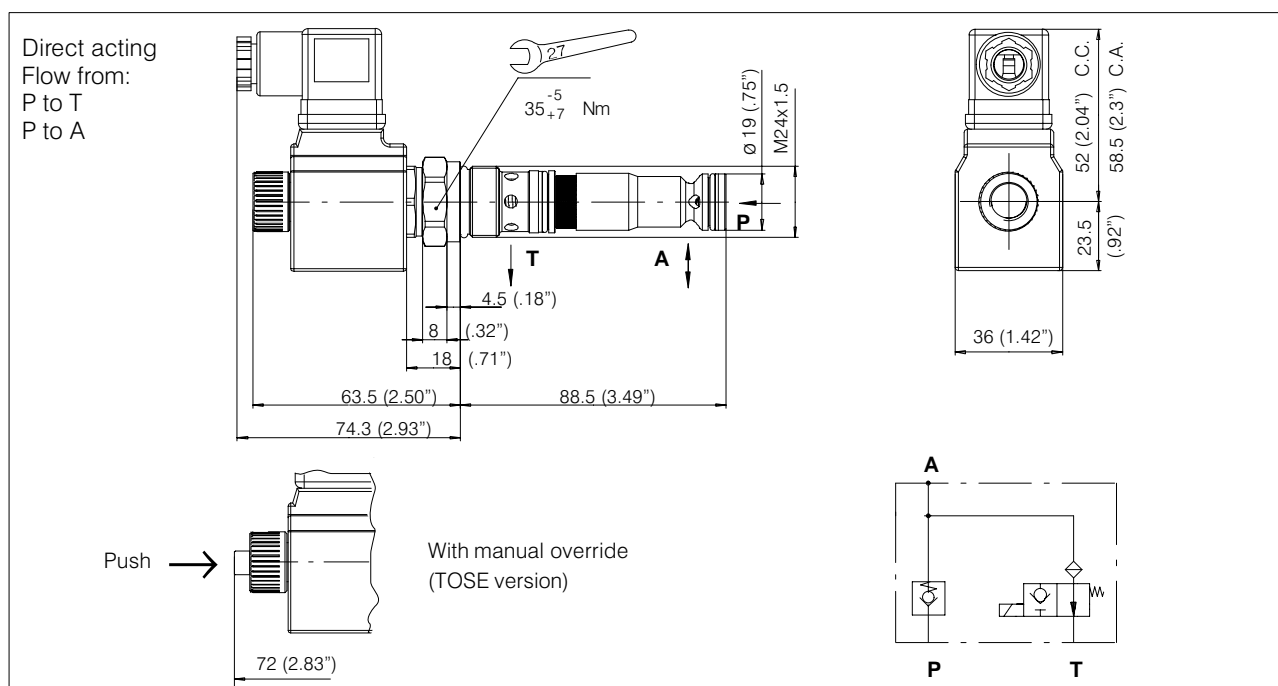

Electric performances	
Max. pressure	230 bar
Max recommended pressure	210 bar
Max. flow	20 l/min. 230 bar
Rated power	27 Watt

Intermittence	ED= 100%
Internal leakage	0-5 drops/min.
Temperature range	-20/+90° C
Opening time (50-210 bar)	15-80 ms.
Closing time (50-210 bar)	10-60 ms.
O-Ring kit code	200.7742.0036.0

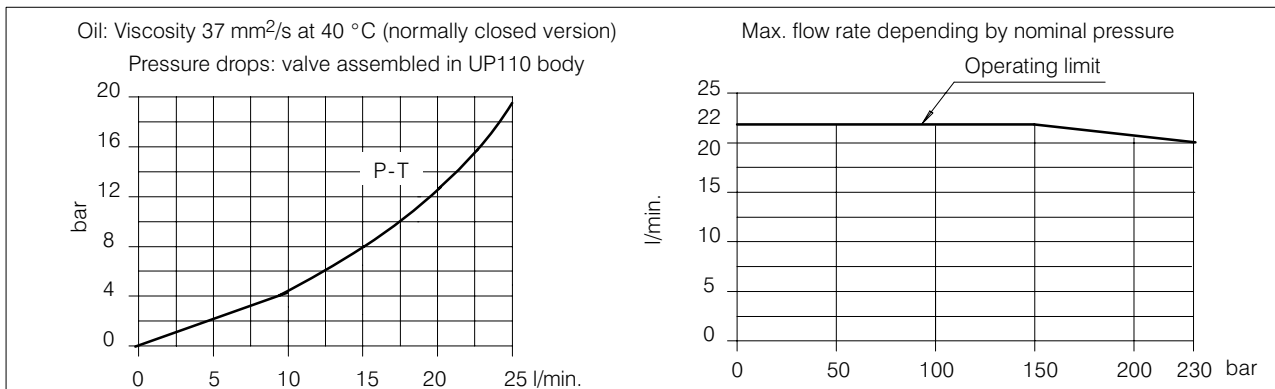

Electrical Version	VAL MF	- TOS	/ 00FC	- 23	- HC
Multifunction valve	MF				Connector type DIN 43650 HC
Normally open	TOS				Voltage - Tolerance: ± 10 %
Normally open with manual override	TOSE				Type
					12 VDC 13
					24 VDC 23
					24 VAC 21
					110 VAC 41
					220 VAC 51
Flow control function					Mechanical part only (without coil and connector) P.M.
Not allowed with the normally open function	00FC				

7.5 Hand lever control

Flow from P to A (solenoid not energized)
Flow from A to T (el. motor must be OFF)

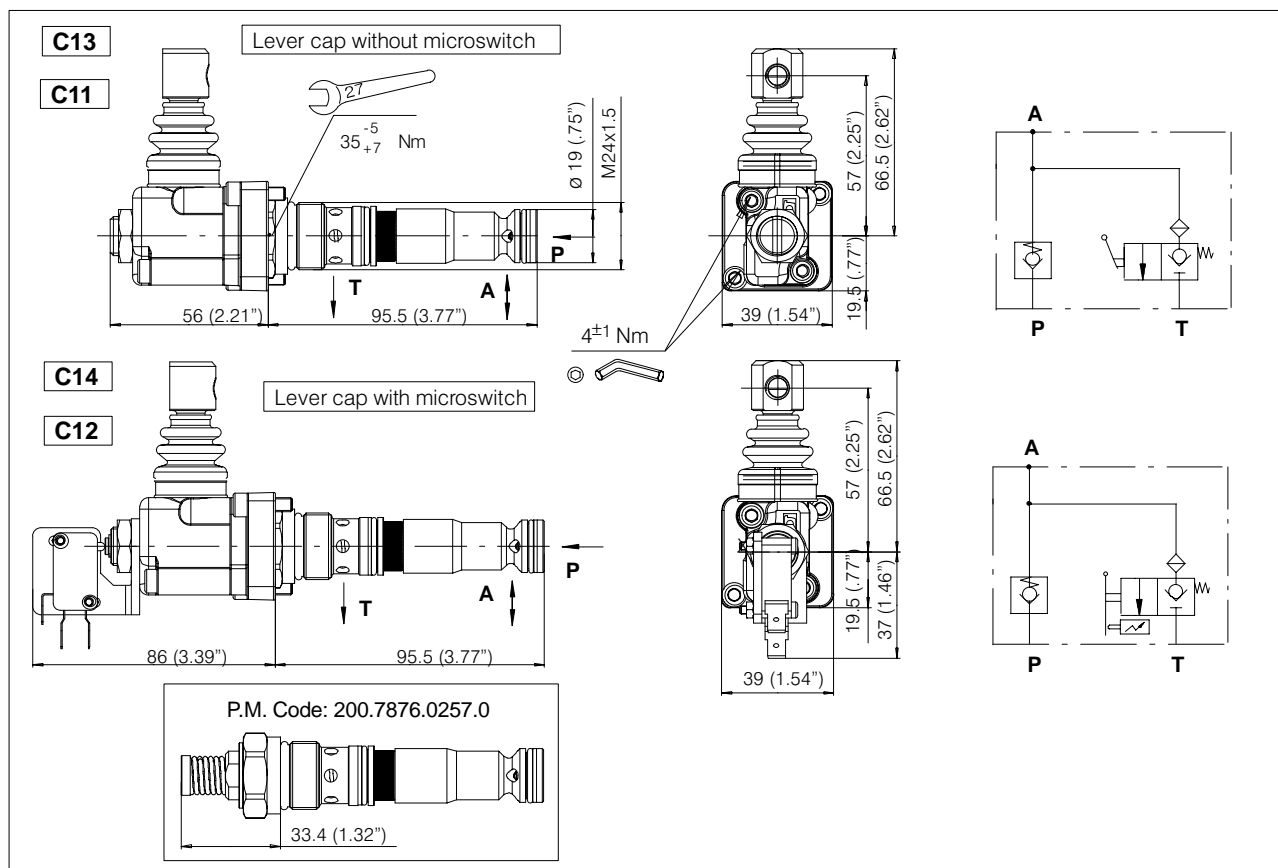

Oil: Viscosity 37mm²/s at 40°C A (normally closed version)

Pressure drops: valve assembled in UP110 body

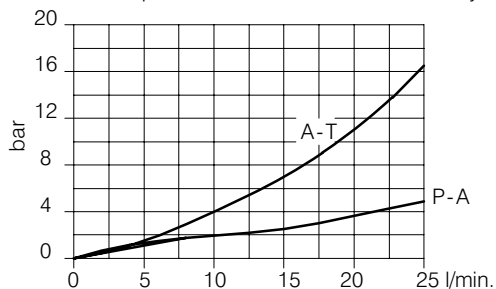

Manual performances

Max. pressure	230 bar
Max recommended pressure	210 bar
Max. flow	25 l/min.
Internal leakage	0-5 drops/min.
Temperature range	-20/+90° C
O-Ring kit code	200.7742.0036.0

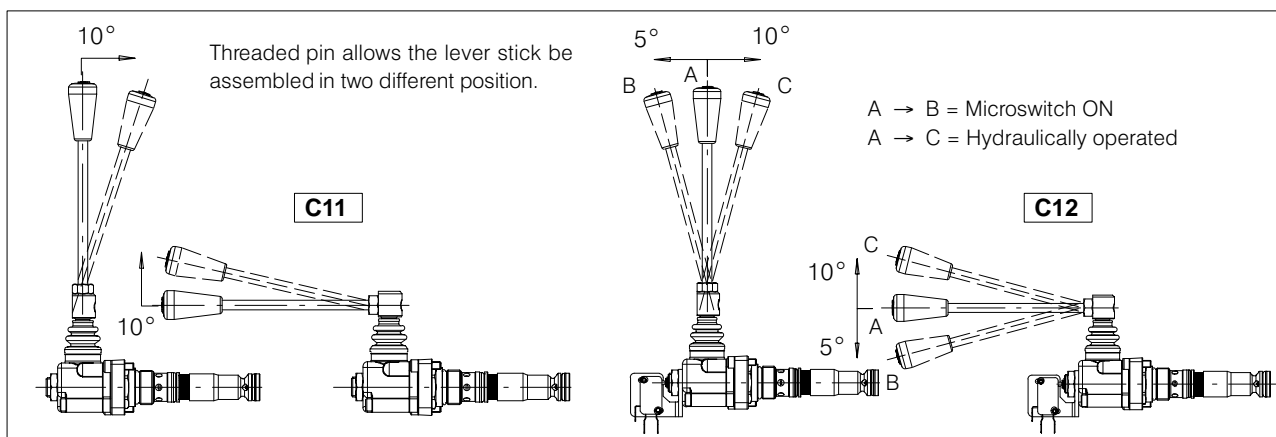
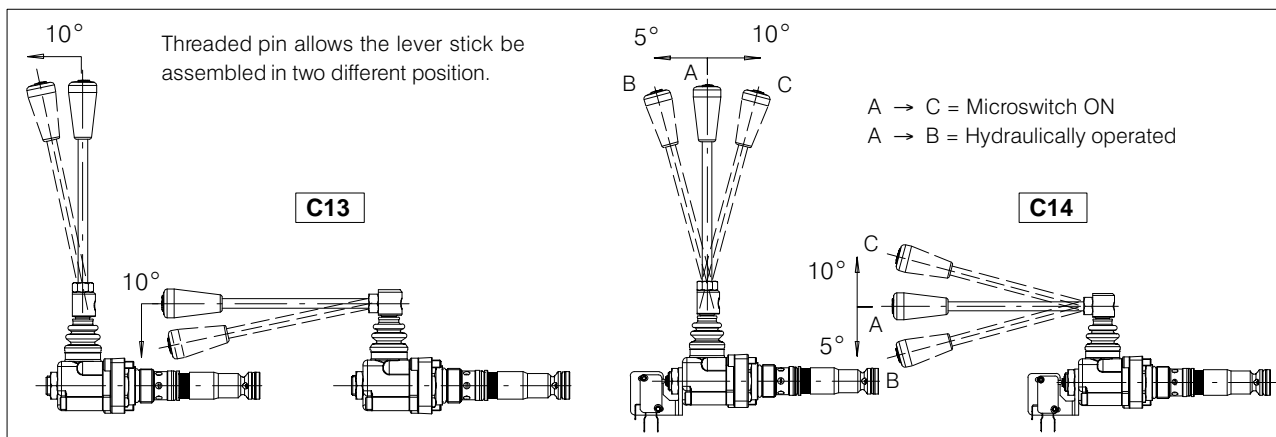

Manual version		VAL MF	-	TVM	/	C13	-	00FC
Multifunction valve	MF							
Normally closed	TVM							
Lever type	Type							
Cap lever without microswitch (standard)	C13							
Cap lever without microswitch	C11							
Cap lever with microswitch (standard)	C14							
Cap lever with microswitch	C12							
Flow control function	Type							
Without flow control function	00FC*							

* for version requiring flow control function see page 18/24

Hand lever mounting positions

Hand lever Lever stick

L	1	0	A	L	0	0	*
---	---	---	---	---	---	---	---

Hand lever Lever stick

L	1	4	A	L	0	0	*
---	---	---	---	---	---	---	---

Hand lever Lever stick

L	1	6	A	L	0	0	*
---	---	---	---	---	---	---	---

Mounting allowed in housing type **K1** Cavity **C**

Type of housing Vers.

1	U	P	1	1	0	K	1		
---	---	---	---	---	---	---	---	--	--

Cavity **C**

7	M	F	-	T	V	M	/	C	1	3	-	0	0	F	C
---	---	---	---	---	---	---	---	---	---	---	---	---	---	---	---

Lever stick

7	Lever stick			
A	L	0	0	1

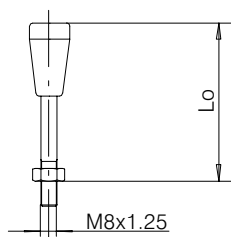

Lo Length	Type	Code
150 mm-5.90 inches	AL001	200.7022.1019.0
200 mm-7.87 inches	AL002	200.7022.1003.0
250 mm-9.84 inches	AL003	200.7022.1005.0
300 mm-11.80 inches	AL004	200.7022.1006.0

7.6 MF valve cavity

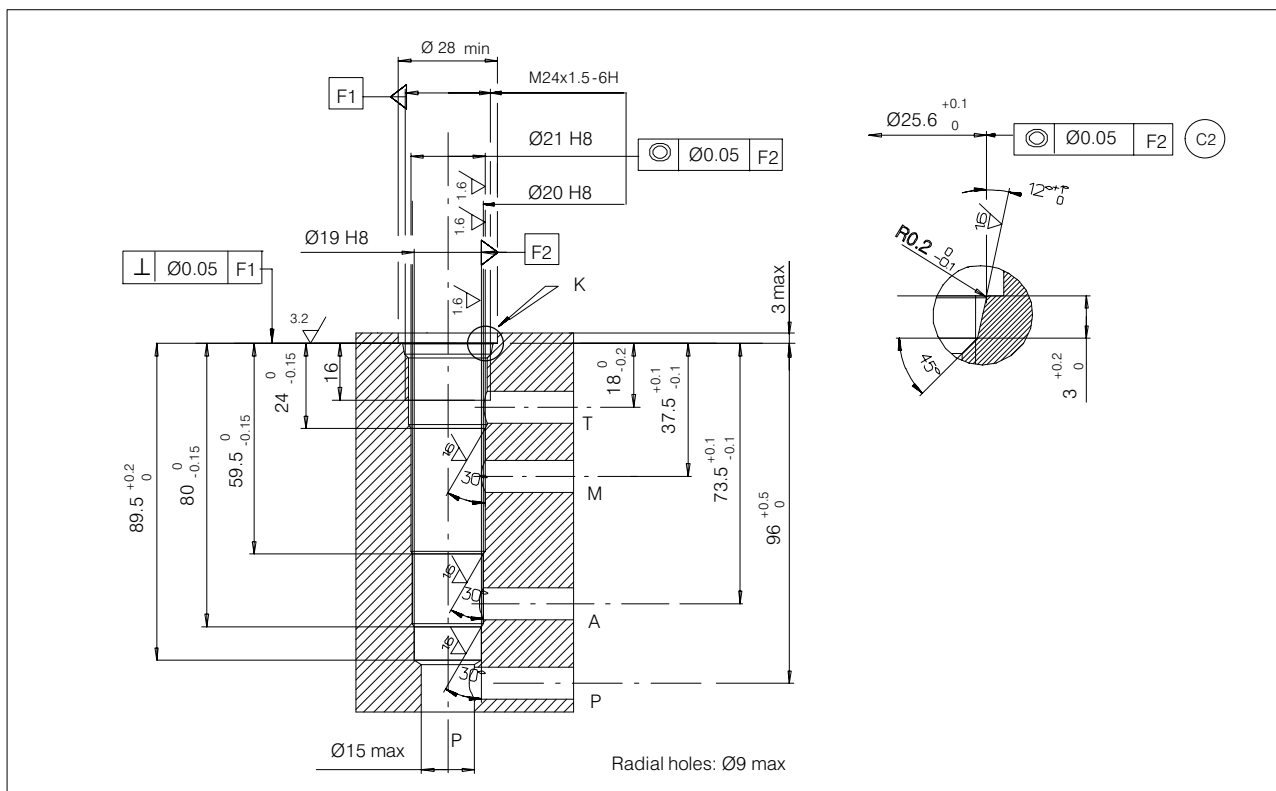

7.7 Directional valve solenoids

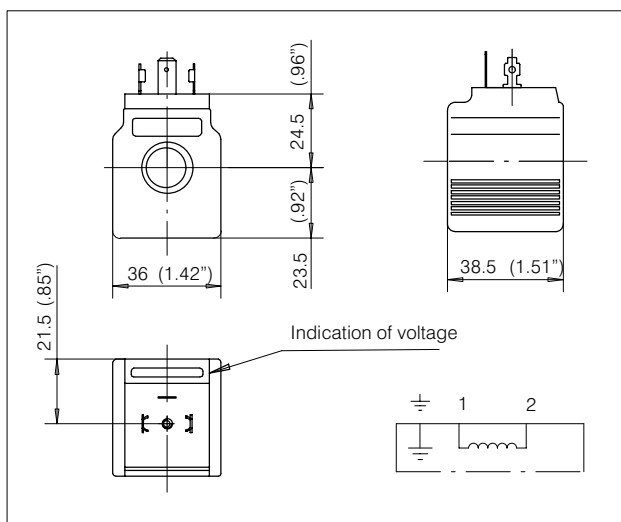

For solenoid valve series	TVS TOS
Wire class	H (VDE0580)
Coil insulation	IP65 (DIN40050)
Duty rating	ED 100%
Connector style	DIN 43650
Stabilized temperature	70 °C
Voltage tolerance	± 10%

Connectors

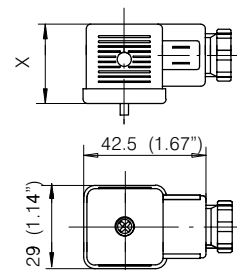

DC
200.5441.1000.9
x = 27.5 mm

AC
200.5441.1001.2
x = 34 mm

Voltage	Nominal voltage	Power (Watt)	Resistance (Ohm)		Current (Ampere)		Coil code	Coil + connector code
			Ambient temp.	Stabil. temp.	Ambient temp.	Stabil. temp.		
12 V. DC	12 V. DC	27.2	5.3	8	2.2	1.5	200.6749.1010.0	200.7749.1047.0
24 V. DC	24 V. DC	27	21.3	32	1.12	0.75	200.6749.2008.0	200.7749.2023.0
24 V. AC	21.6 V. DC	27.1	17.2	26	1.25	0.83	200.6748.2005.0	200.7748.2018.0
110 V. AC	98 V. DC	27	355	530	0.27	0.18	200.6748.4005.0	200.7748.4018.0
220 V. DC	198 V. DC	27.6	1422	2130	0.14	0.10	200.6748.6006.0	200.7748.6020.0

8 Example of hydraulic power pack ordering code

1	Type of housing	Vers.	U P 1 1 0 / K 1 G 2 0 1		
2	Pump	Hi-Lo	Series	A P 1 0 0 / 2 . 5 S 3 0 9	
3	Tank	Fitting	Pos.	P - 0 6 0 Q - A B T P 0 1	
4	Suction assembly kit	Tank fixing kit			
5	Electric motor	Pos.	Relay	Pos.	C 2 4 0 A K / Y 0 A
6	Drive	E 1 4 5			
7	Cavity a	Cavity c	1 8 V M 0 1 M F - T V S / 0 9 F C - 2 3 - H C		
	Hand lever	Stick lever	Volt	2 3	

Cavities identification

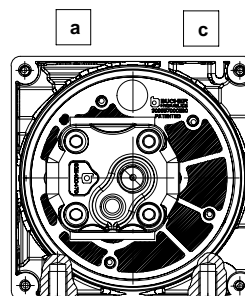

Composition of product code

UP110/K1G201 · AP100/2.5 · S309
 P-060Q-ABT · P01 · C240AK/Y0 · A · E145

- a) 18VM01
- c) MF-TVS/09FC-23-HC

Product identification plate

Rotation : \curvearrowright → S = Counterclockwise rotation

S 4P	← Year and month
200.222393016	← Code
UP110/K1G2-01 2.5 CC/REV	← Product description

Manufacturing month	Manufacturing year					
	2002	2003	2004	2005	2006	2007
January	2M	3M	4M	5M	6M	7M
February	2N	3N	4N	5N	6N	7N
March	2P	3P	4P	5P	6P	7P
April	2Q	3Q	4Q	5Q	6Q	7Q
May	2R	3R	4R	5R	6R	7R
June	2S	3S	4S	5S	6S	7S
July	2T	3T	4T	5T	6T	7T
August	2U	3U	4U	5U	6U	7U
September	2V	3V	4V	5V	6V	7V
October	2Z	3Z	4Z	5Z	6Z	7Z
November	2X	3X	4X	5X	6X	7X
December	2Y	3Y	4Y	5Y	6Y	7Y

BUCHER HYDRAULICS

www.bucherhydraulics.com

Germany

Phone +49 7742 85 20
Fax +49 7742 71 16
info.de@bucherhydraulics.com

France

Phone +33 389 64 22 44
Fax +33 389 65 28 78
info.fr@bucherhydraulics.com

Netherlands

Phone +31 79 34 26 24 4
Fax +31 79 34 26 28 8
info.nl@bucherhydraulics.com

UK

Phone +44 24 76 35 35 61
Fax +44 24 76 35 35 72
info.uk@bucherhydraulics.com

USA

Phone +1 262 605 82 80
Fax +1 262 605 82 78
info.wi@bucherhydraulics.com

Switzerland

Phone +41 33 67 26 11 1
Fax +41 33 67 26 10 3
info.ch@bucherhydraulics.com

Italy

Phone +39 0522 92 84 11
Fax +39 0522 51 32 11
info.it@bucherhydraulics.com

Austria

Phone +43 6216 44 97
Fax +43 6216 44 97 4
info.at@bucherhydraulics.com

China

Phone +86 10 64 44 32 38
Fax +86 10 64 44 32 35
info.bj@bucherhydraulics.com

Product Center (Elevator)

Phone +41 41 757 03 33
Fax +41 41 755 16 49
info.nh@bucherhydraulics.com

We reserve the right of modification without prior notice.