

Contents

Shuttle Valves

	SERIES	CAVITY	DESCRIPTION	FLOW LPM/GPM	PRESSURE BAR/PSI	PAGE NO.
	KSWA3	SW-3	Ball Insert Type	9.5/2.5	420/6000	SH3
	K2A005	3Z	Poppet Insert Type	38/10	350/5000	SH4
	CS041B	C04-3	Cartridge Shuttle	3.8/1.0	207/3000	SH5
	K02A3	C08-3	Cartridge Shuttle	50/13	420/6000	SH6
	CSH101B	C10-3	Cartridge Shuttle	38/10	350/5000	SH7
	ASH-04		In-Line Shuttle,-4 Male JIC	11/3	207/3000	SH8-SH9
	ASH-06		In-Line Shuttle,-6T	22/6	207/3000	SH8-SH9
	K04B3	C10-3	Spool Type Shuttle	90/24	420/6000	SH10
	K04D3	C10-3	Spool Type Shuttle	90/24	420/6000	SH11
	K04C3	C10-4	Spool Type, Spring Centered, All Ports Closed	100/26	420/6000	SH12
	K3A125	3J	Spool Type, Spring Centered, All Ports Closed	175/46	350/5000	SH13
	K04F3	C10-4	Spool Type, Spring Centered, All Ports Open	100/26	420/6000	SH14
	K04G3	C10-4	Spool Type Shuttle, Inverse	50/13	350/5000	SH15

- CV**
Check Valves
- SH**
Shuttle Valves
- LM**
Load/Motor Controls
- FC**
Flow Controls
- PC**
Pressure Controls
- LE**
Logic Elements
- DC**
Directional Controls
- MV**
Manual Valves
- SV**
Solenoid Valves
- PV**
Proportional Valves
- CE**
Coils & Electronics
- BC**
Bodies & Cavities
- TD**
Technical Data

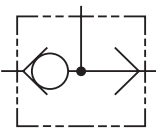
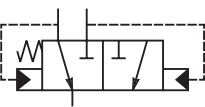
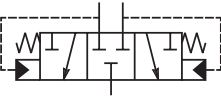
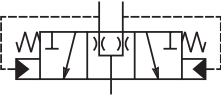
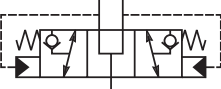

CV

Check Valves

SH

Shuttle Valves

LM

Load/Motor Controls

FC

Flow Controls

PC

Pressure Controls

LE

Logic Elements

DC

Directional Controls

MV

Manual Valves

SV

Solenoid Valves

PV

Proportional Valves

CE

Coils & Electronics

BC

Bodies & Cavities

TD

Technical Data

INTRODUCTION:

Shuttle valves accept flow from two different sources and divert the highest pressure to a single outlet port. Shuttle valves are commonly used in Load Sensing circuits as well as Brake circuits. Parker offers many different types of shuttles, including ball type, poppet type, spool type. There are a number of configurations available such as cartridge type, insert type, and an in-line version.

Ball Type - Cartridge Style

The valve consists of a steel ball that can seal against one of two adjacent seats, providing a path from the highest pressure signal to another function.

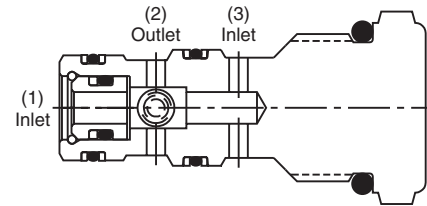
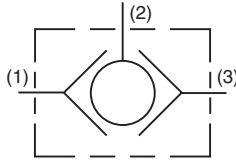

When one inlet port is pressurized, the ball or poppet is forced against the opposite seat, blocking that inlet and providing a flow path to the outlet port.

Poppet Type - Insert Style

This shuttle performs the same function, but allows for higher flow rates due to poppet design.

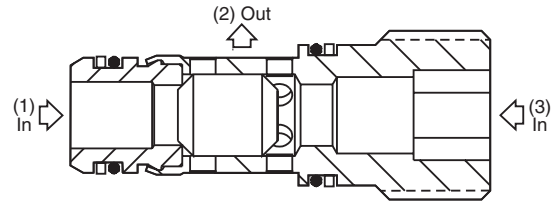
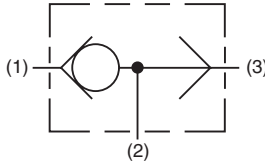

In-Line Type

This shuttle variant performs the same function in a self-contained body. It can be mounted anywhere on the machine.

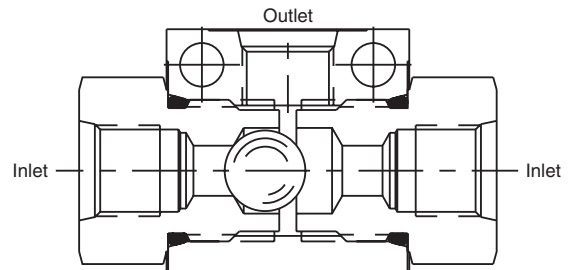
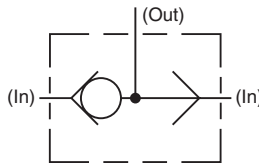

Spool Type - Centered or Spring Offset

The spool type shuttle allows for higher flow rates. These are 2 position valves.

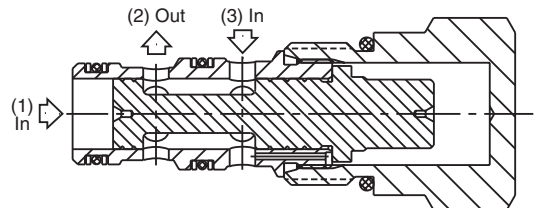
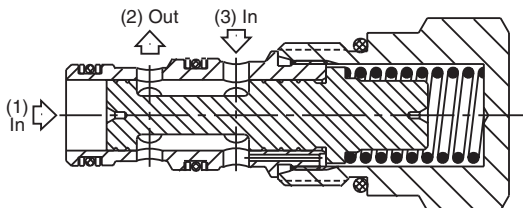
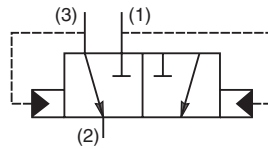
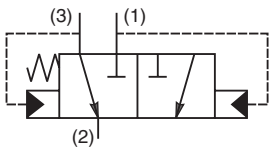

3 Way 2 Position Spool type shuttles are designed to direct flow in such a way as to allow higher pressure signals to open the lower pressure port and connect it to the common outlet port. These spring centered valves will shift when pressure at either end of the spool exceed the spring setting. These are typically used in transmission hot oil shuttle circuits.

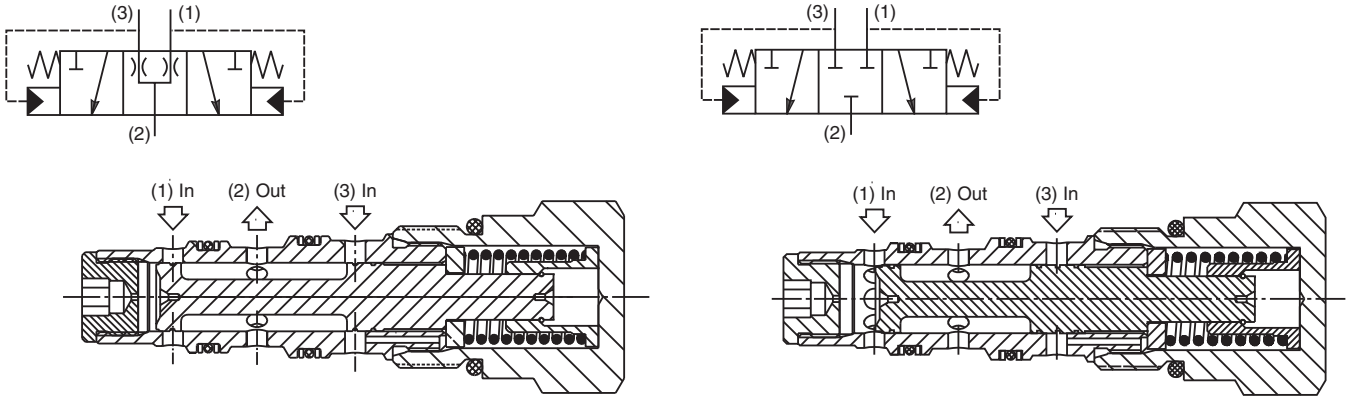

CV
Check Valves
SH
Shuttle Valves
LM
Load/Motor Controls
FC
Flow Controls
PC
Pressure Controls
LE
Logic Elements
DC
Directional Controls
MV
Manual Valves
SV
Solenoid Valves
PV
Proportional Valves
CE
Coils & Electronics
BC
Bodies & Cavities
TD
Technical Data

Technical Information

General Description

Ball Type, Two Position, Three Way Shuttle Valve.
For additional information see Technical Tips on pages SH1-SH2.

Features

- Compact, cost effective design
- Ball type construction for maximum durability
- Minimal leakage - less than 3 drops/min.
- Contamination tolerant
- Hardened working parts for maximum durability
- All external parts zinc plated

Performance Curve

Pressure Drop vs. Flow (Through cartridge only)

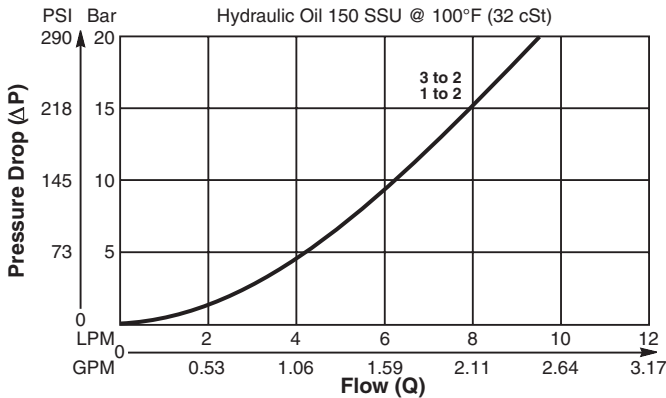

Specifications

Rated Flow	9.5 LPM (2.5 GPM)
Nominal Flow @ 7 Bar (100 PSI)	5 LPM (1.32 GPM)
Maximum Inlet Pressure	420 Bar (6000 PSI)
Cartridge Material	All parts steel. All operating parts hardened steel.
Operating Temp. Range/Seals	-40°C to +93.3°C (Nitrile, Buna-N) (-40°F to +200°F) -31.7°C to +121.1°C (Fluorocarbon) (-25°F to +250°F)
Fluid Compatibility/Viscosity	Mineral-based or synthetic with lubricating properties at viscosities of 45 to 2000 SSU (6 to 420 cSt)
Filtration	ISO code 16/13, SAE Class 4 or better
Approx. Weight	.01 kg (.02 lbs.)
Cavity	CAVSW-3 (See BC Section for more details)

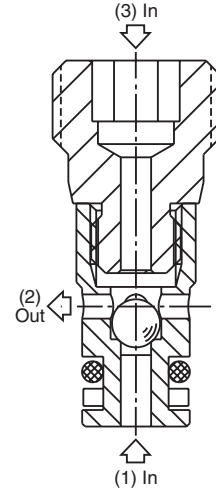
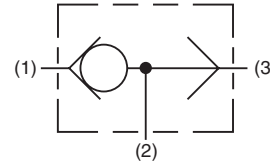

Dimensions Millimeters (Inches)

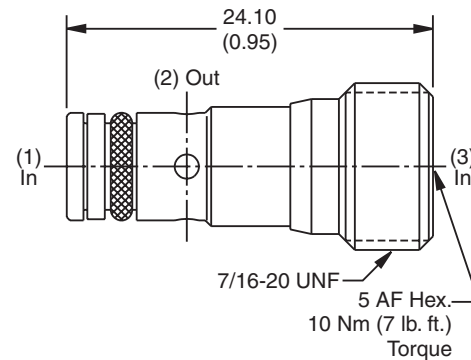

Application

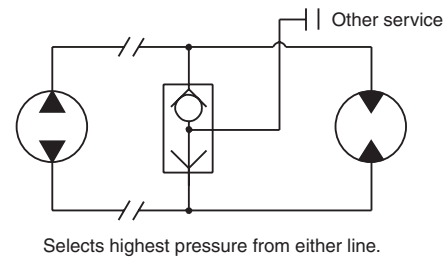

Ordering Information

KSWA3 Shuttle Valve

Seals

Order Bodies Separately

LB10 Line Body Porting Body Material

Code	Porting
815	1/4" SAE
816	1/4" BSP

Code	Body Material
A	Aluminum
S	Steel

CV Check Valves

SH Shuttle Valves

LM Load/Motor Controls

FC Flow Controls

PC Pressure Controls

LE Logic Elements

DC Directional Controls

MV Manual Valves

SV Solenoid Valves

PV Proportional Valves

CE Coils & Electronics

BC Bodies & Cavities

TD Technical Data

Technical Information

- CV** Check Valves
- SH** Shuttle Valves
- LM** Load/Motor Controls
- FC** Flow Controls
- PC** Pressure Controls
- LE** Logic Elements
- DC** Directional Controls
- MV** Manual Valves
- SV** Solenoid Valves
- PV** Proportional Valves
- CE** Coils & Electronics
- BC** Bodies & Cavities
- TD** Technical Data

General Description

Poppet Type, Two Position, Three Way Shuttle Valve. For additional information see Technical Tips on pages SH1-SH2.

Features

- High flow capacity
- Compact cost effective design
- Poppet type construction for minimal leakage
- Contamination tolerant
- All external parts zinc plated

Performance Curve

Pressure Drop vs. Flow (Through cartridge only)

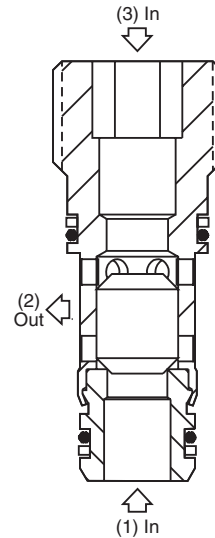
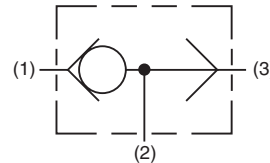
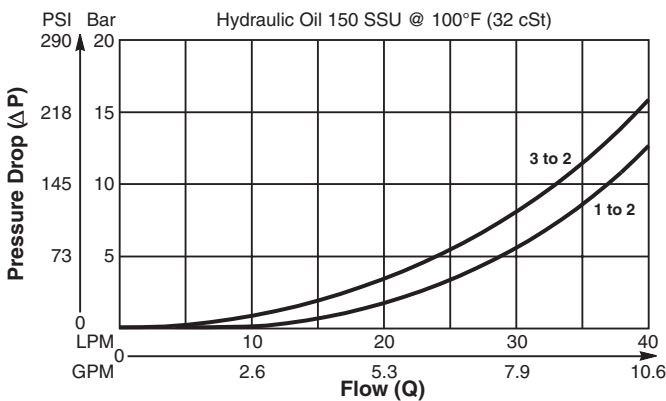

Dimensions Millimeters (Inches)

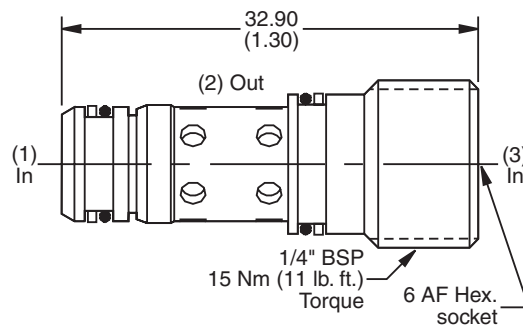

Specifications

Rated Flow	38 LPM (10 GPM)
Nominal Flow @ 7 Bar (100 PSI)	28 LPM (7.4 GPM)
Maximum Inlet Pressure	350 Bar (5000 PSI)
Cartridge Material	Steel operating parts, hardened steel poppet.
Operating Temp. Range/Seals	-40°C to +93.3°C (Nitrile, Buna-N) (-40°F to +200°F) -31.7°C to +121.1°C (Fluorocarbon) (-25°F to +250°F)
Fluid Compatibility/Viscosity	Mineral-based or synthetic with lubricating properties at viscosities of 45 to 2000 SSU (6 to 420 cSt)
Filtration	ISO code 16/13, SAE Class 4 or better
Approx. Weight	.02 kg (.04 lbs.)
Cavity	3Z (See BC Section for more details)

Application

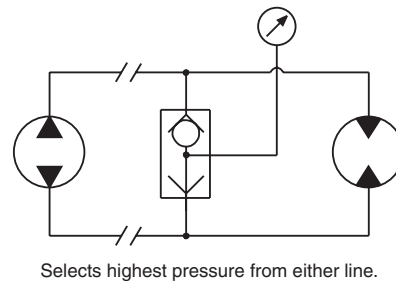

Ordering Information

K2A005 Shuttle Valve

Seals

Order Bodies Separately

LB10 Line Body Porting Body Material

Code	Porting
313	1/4" BSP
320	1/4" SAE

Code	Body Material
A	Aluminum
S	Steel

Technical Information

General Description

Cartridge Style Shuttle Valve. For additional information see Technical Tips on pages SH1-SH2.

Features

- Hardened, precision ground parts for durability
- Rapid response to load direction changes
- All external parts zinc plated

Performance Curve

Pressure Drop vs. Flow (Through cartridge only)

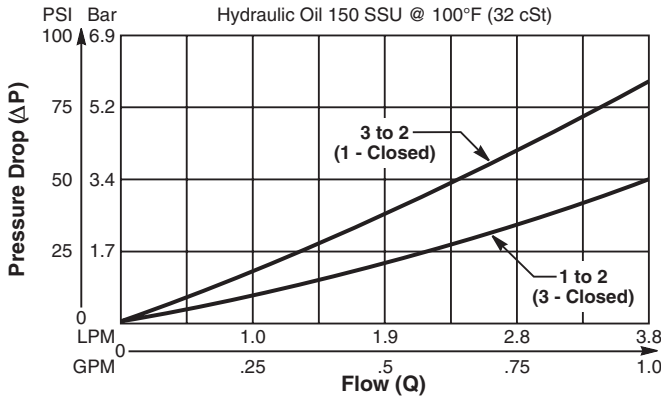

Specifications

Rated Flow	3.8 LPM (1 GPM)
Nominal Flow @ 7 Bar (100 PSI)	
Maximum Inlet Pressure	207 Bar (3000 PSI)
Leakage at 150 SSU (32 cSt)	5 drops/min. (.33 cc/min.) at 207 Bar (3000 PSI)
Cartridge Material	All parts steel. All operating parts hardened steel.
Operating Temp. Range/Seals	-40°C to +93.3°C (Nitrile) (-40°F to +200°F) -31.7°C to +121.1°C (Fluorocarbon) (-25°F to +250°F)
Fluid Compatibility/Viscosity	Mineral-based or synthetic with lubricating properties at viscosities of 45 to 2000 SSU (6 to 420 cSt)
Filtration	ISO code 16/13, SAE Class 4 or better
Approx. Weight	.02 kg (.04 lbs.)
Cavity	C04-3 (See BC Section for more details)
Form Tool	Rougher NFT04-3R Finisher NFT04-3F

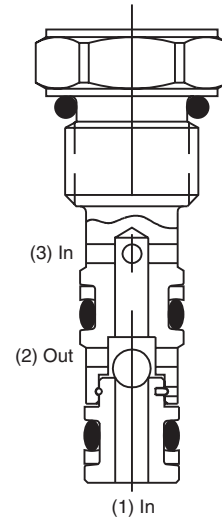
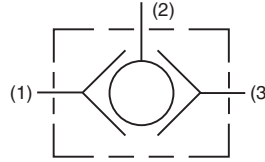

Dimensions Millimeters (Inches)

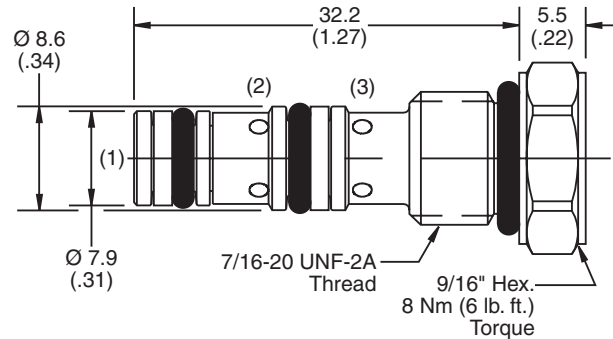

Ordering Information

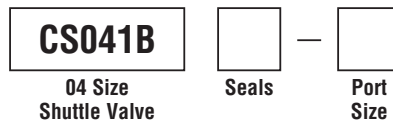

Code	Seals / Kit No.
Omit	Nitrile / (SK03-3)
V	Fluorocarbon / (SK04-3V)

Code	Port Size	Body Part No.
Omit	Cartridge Only	
A4T	SAE-4	(B04-3-A4T)

- CV** Check Valves
- SH** Shuttle Valves
- LM** Load/Motor Controls
- FC** Flow Controls
- PC** Pressure Controls
- LE** Logic Elements
- DC** Directional Controls
- MV** Manual Valves
- SV** Solenoid Valves
- PV** Proportional Valves
- CE** Coils & Electronics
- BC** Bodies & Cavities
- TD** Technical Data

Technical Information

CV

Check Valves

SH

Shuttle Valves

LM Load/Motor Controls

FC

Flow Controls

PC

Pressure Controls

LE

Logic Elements

DC

Directional Controls

MV

Manual Valves

SV

Solenoid Valves

PV

Proportional Valves

CE

Cats & Electronics

BC

Bodies & Cavities

TD

Technical Data

General Description

Ball Type, Two Position, Three Way Shuttle Valve. For additional information see Technical Tips on pages SH1-SH2.

Features

- High flow capacity
- Ball type construction for maximum wear resistance and greater durability
- Minimal leakage - less than 3 drops/min.
- Contamination tolerant
- All external parts zinc plated

Performance Curve

Pressure Drop vs. Flow (Through cartridge only)

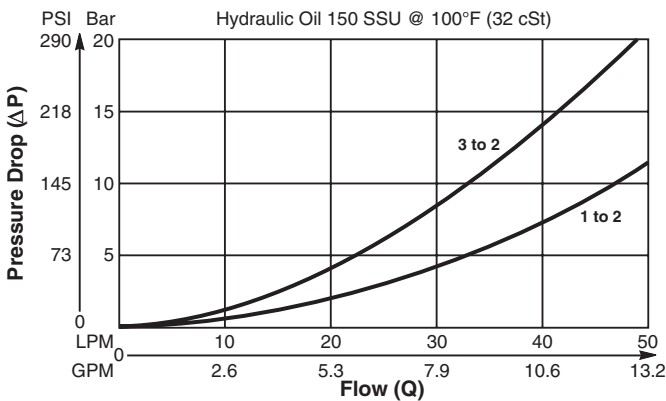

Specifications

Rated Flow	50 LPM (13 GPM)
Nominal Flow @ 7 Bar (100 PSI)	27 LPM (7 GPM)
Maximum Inlet Pressure	420 Bar (6000 PSI)
Cartridge Material	Steel operating parts, hardened steel poppet.
Operating Temp. Range/Seals	-40°C to +93.3°C (Nitrile, Buna-N) (-40°F to +200°F) -31.7°C to +121.1°C (Fluorocarbon) (-25°F to +250°F)
Fluid Compatibility/Viscosity	Mineral-based or synthetic with lubricating properties at viscosities of 45 to 2000 SSU (6 to 420 cSt)
Filtration	ISO code 16/13, SAE Class 4 or better
Approx. Weight	.07 kg (.15 lbs.)
Cavity	C08-3 (See BC Section for more details)

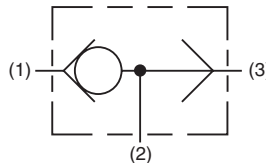
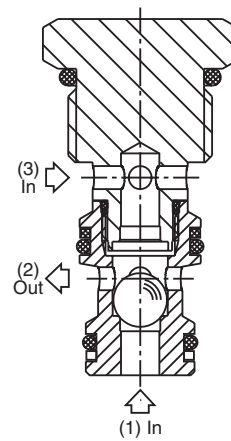

Dimensions

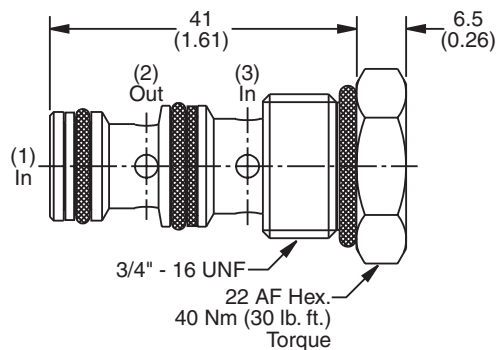

Application

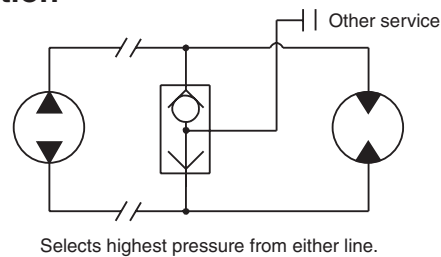

Ordering Information

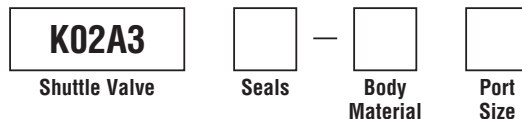

Code	Seals / Kit No.
N	Nitrile, Buna-N / (SK30521N-1)
V	Fluorocarbon / (SK30521V-1)

Code	Body Material
Omit	Steel
A	Aluminum

Code	Port Size	Body Part No.
Omit		Cartridge Only
4P	1/4" NPTF	(B08-3-*4P)
4T	SAE-4	(B08-3-*4T)
6T	SAE-6	(B08-3-*6T)
6B	3/8" BSPG	(B08-3-*6B)

* Add "A" for aluminum, omit for steel.

General Description

Cartridge Style Shuttle Valve. For additional information see Technical Tips on pages SH1-SH2.

Features

- Hardened, precision ground parts for durability
- 5000 PSI rated
- All external parts zinc plated

Performance Curve

Pressure Drop vs. Flow (Through cartridge only)

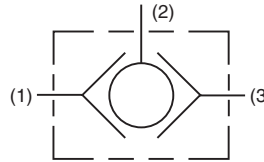
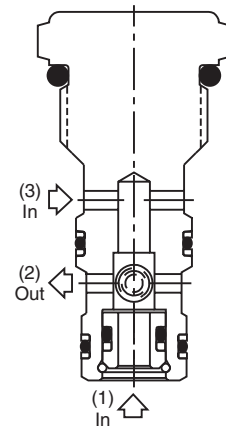
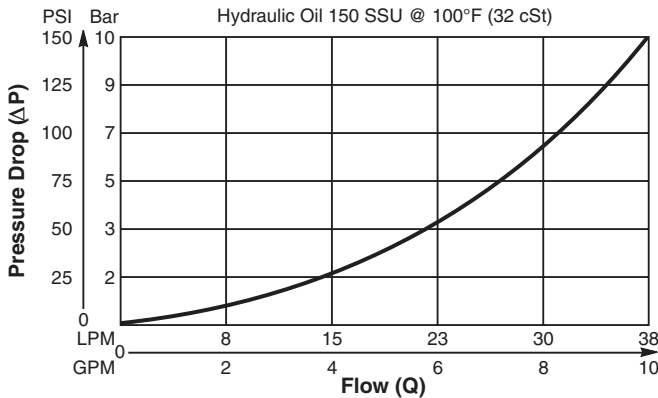

Specifications

Rated Flow	38 LPM (10 GPM)
Maximum Inlet Pressure	350 Bar (5000 PSI)
Leakage at 150 SSU (32 cSt)	10 drops/min. (.67 cc/min.) at 350 Bar (5000 PSI)
Cartridge Material	All parts steel. All operating parts hardened steel.
Operating Temp. Range/Seals	-40°C to +93.3°C (Nitrile) (-40°F to +200°F) -31.7°C to +121.1°C (Fluorocarbon) (-25°F to +250°F)
Fluid Compatibility/Viscosity	Mineral-based or synthetic with lubricating properties at viscosities of 45 to 2000 SSU (6 to 420 cSt)
Filtration	ISO code 16/13, SAE Class 4 or better
Approx. Weight	.14 kg (0.3 lbs.)
Cavity	C10-3 (See BC Section for more details)
Form Tool	Rougher NFT10-3R Finisher NFT10-3F

Dimensions Millimeters (Inches)

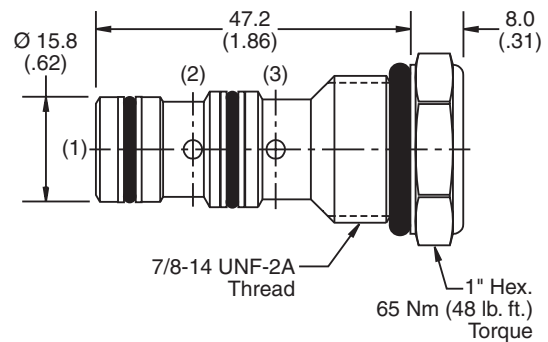

Ordering Information

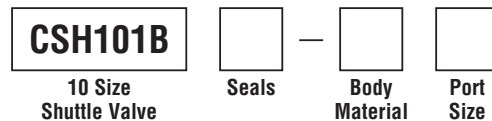

Code	Seals / Kit No.
Omit	Nitrile / (SK10-3N)
V	Fluorocarbon / (SK10-3V)

Code	Body Material
Omit	Steel
A	Aluminum

Code	Port Size	Body Part No.
Omit	Cartridge Only	
4P	1/4" NPTF	(B10-3-*4P)
6P	3/8" NPTF	(B10-3-*6P)
8P	1/2" NPTF	(B10-3-*8P)
6T	SAE-6	(B10-3-*6T)
8T	SAE-8	(B10-3-*8T)
6B	3/8" BSPG	(B10-3-6B)†
8B	1/2" BSPG	(B10-3-*8B)

* Add "A" for aluminum, omit for steel.
† Steel body only.



CV Check Valves

SH Shuttle Valves

LM Load/Motor Controls

FC Flow Controls

PC Pressure Controls

LE Logic Elements

DC Directional Controls

MV Manual Valves

SV Solenoid Valves

PV Proportional Valves

CE Coils & Electronics

BC Bodies & Cavities

TD Technical Data

Technical Information

- CV** Check Valves
- SH** Shuttle Valves
- LM** Load/Motor Controls
- FC** Flow Controls
- PC** Pressure Controls
- LE** Logic Elements
- DC** Directional Controls
- MV** Manual Valves
- SV** Solenoid Valves
- PV** Proportional Valves
- CE** Coils & Electronics
- BC** Bodies & Cavities
- TD** Technical Data

General Description

In-Line Style Shuttle Valve. For additional information see Technical Tips on pages SH1-SH2.

Features

- Compact in size
- In-line mounting
- Easily adaptable to various applications
- All external parts zinc plated

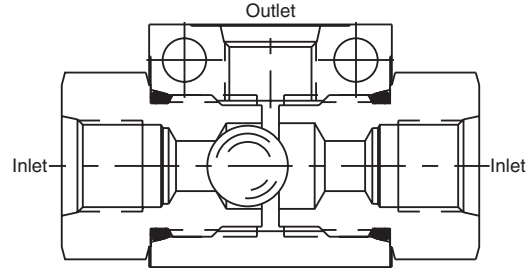
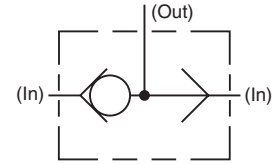
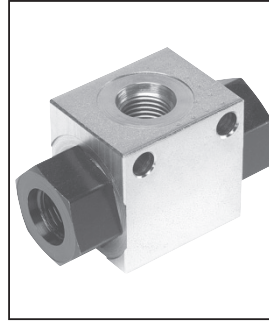

Specifications

Rated Flow	ASH-04-3 11 LPM (3 GPM) ASH-06-2 22 LPM (6 GPM)
Maximum Inlet Pressure	207 Bar (3000 PSI)
Leakage at 150 SSU (32 cSt)	5 drops/min. (.33 cc/min.) at 172 Bar (2500 PSI)
Body Material	Steel (Chromate Plated)
Operating Temp. Range/Seals	-40°C to +93.3°C (-40°F to +200°F) (Nitrile Seals Only)
Fluid Compatibility/Viscosity	Mineral-based or synthetic with lubricating properties at viscosities of 45 to 2000 SSU (6 to 420 cSt)
Filtration	ISO code 16/13, SAE Class 4 or better
Approx. Weight	ASH-04-3 .36 kg (0.8 lbs.) ASH-06-2 .45 kg (1.0 lbs.)

Performance Curves

Flow vs. Pressure Drop (Through cartridge only)

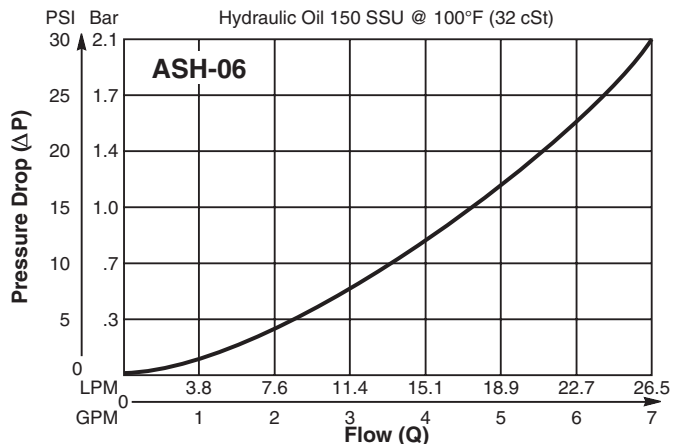
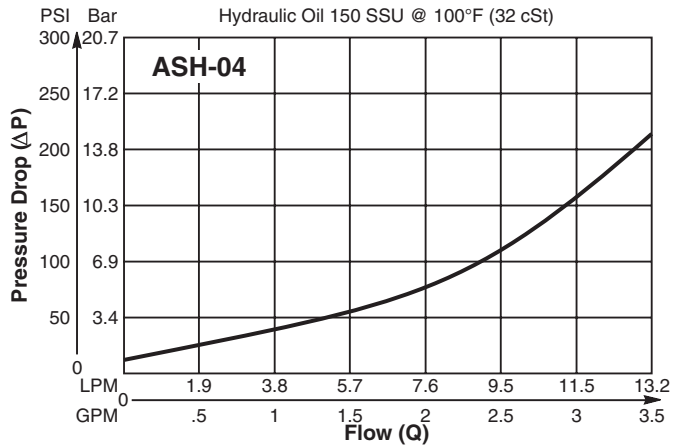

Technical Information

Dimensions Millimeters (Inches)

ASH-04-3

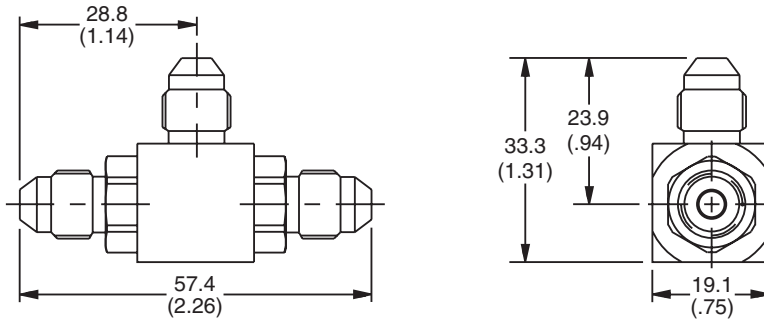

ASH-06-2

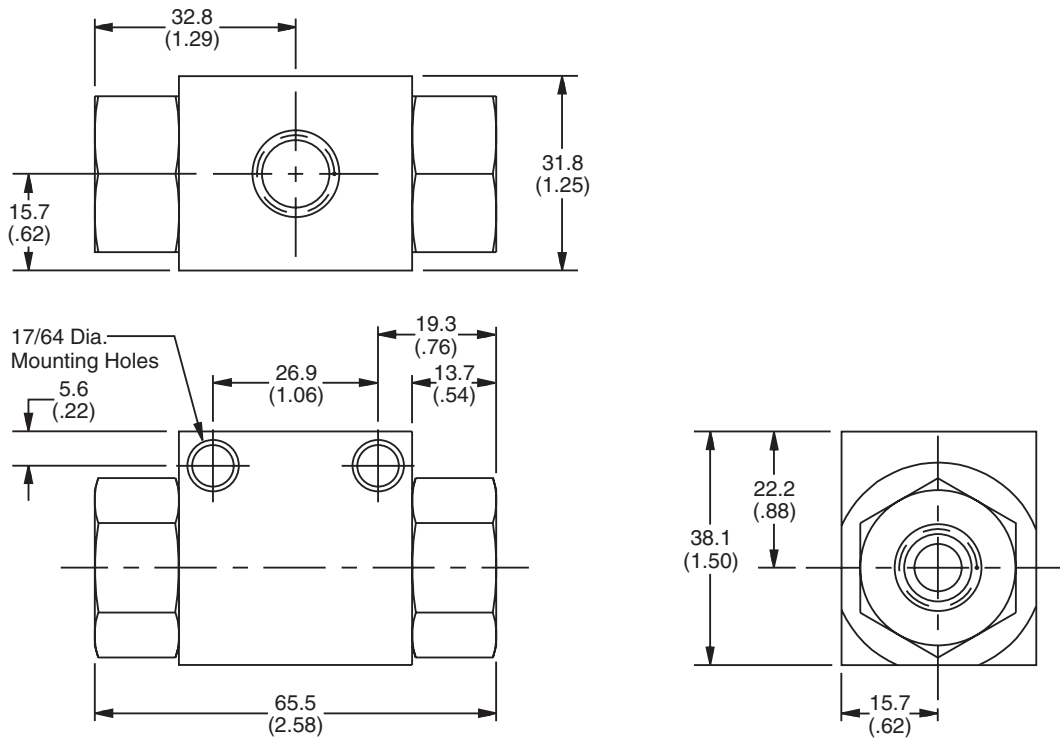

Ordering Information

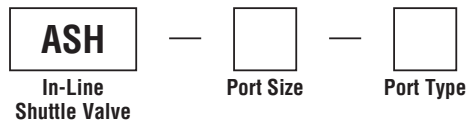

Code	Port Size
04	1/4" JIC
06	SAE-6

Code	Port Type
2	SAE (#6)
3	Male JIC (1/4" only)

CV

Check Valves

SH

Shuttle Valves

LM

Load/Motor Controls

FC

Flow Controls

PC

Pressure Controls

LE

Logic Elements

DC

Directional Controls

MV

Manual Valves

SV

Solenoid Valves

PV

Proportional Valves

CE

Coils & Electronics

BC

Bodies & Cavities

TD

Technical Data

Technical Information

CV

Check Valves

SH

Shuttle Valves

LM Load/Motor Controls

FC

Flow Controls

PC

Pressure Controls

LE

Logic Elements

DC

Directional Controls

MV

Manual Valves

SV

Solenoid Valves

PV

Proportional Valves

CE

Cats & Electronics

BC

Bodies & Cavities

TD

Technical Data

General Description

Two Position, Three Way, Spring Offset Shuttle Valve. For additional information see Technical Tips on pages SH1-SH2.

Features

- High flow capacity
- Various switching pressures available
- Used as automatic brake release valve on motors, where brake release is required at pressures between 1 & 10 bar.
- Hardened working parts for maximum durability
- All external parts zinc plated

Performance Curve

Pressure Drop vs. Flow (Through cartridge only)

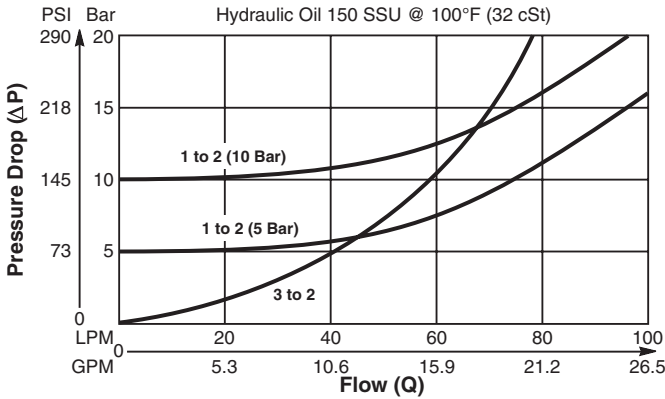

Specifications

Rated Flow	90 LPM (24 GPM)
Nominal Flow @ 7 Bar (100 PSI)	50 LPM (13 GPM)
Maximum Inlet Pressure	420 Bar (6000 PSI)
Cartridge Material	All parts steel. All operating parts hardened steel.
Operating Temp. Range/Seals	-40°C to +93.3°C (Nitrile, Buna-N) (-40°F to +200°F) -31.7°C to +121.1°C (Fluorocarbon) (-25°F to +250°F)
Fluid Compatibility/Viscosity	Mineral-based or synthetic with lubricating properties at viscosities of 45 to 2000 SSU (6 to 420 cSt)
Filtration	ISO code 16/13, SAE Class 4 or better
Approx. Weight	.14 kg (.31 lbs.)
Cavity	C10-3 (See BC Section for more details)

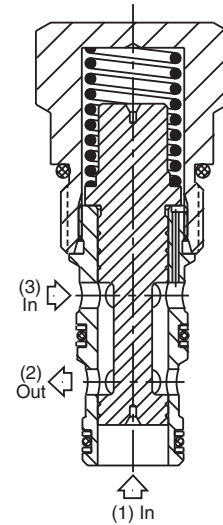
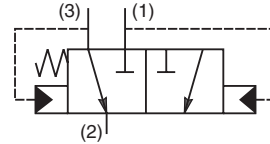

Dimensions Millimeters (Inches)

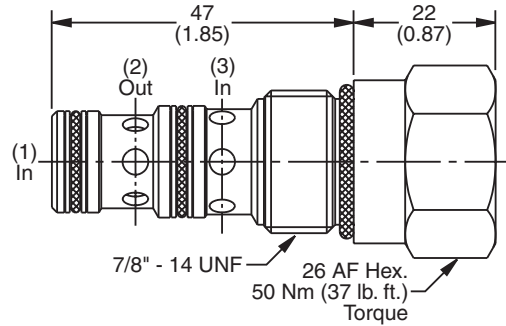

Application

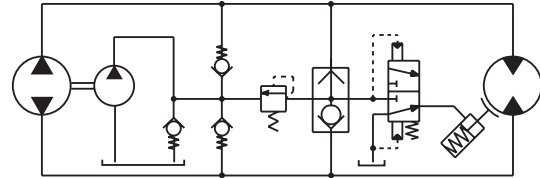

Brake release at various switching pressures.

Ordering Information

K04B3 - - - -

Shuttle Valve Switching Pressure Seals Body Material Port Size

Code	Switching Pressure
5.0	5.0 Bar (73 PSI) Std.
10.0	10.0 Bar (145 PSI)

Code	Seals / Kit No.
N	Nitrile, Buna-N / (SK30505N-1)
V	Fluorocarbon / (SK30505V-1)

Code	Body Material
Omit	Steel
A	Aluminum

Code	Port Size	Body Part No.
Omit	Cartridge Only	
4P	1/4" NPTF	(B10-3-*4P)
6P	3/8" NPTF	(B10-3-*6P)
8P	1/2" NPTF	(B10-3-*8P)
6T	SAE-6	(B10-3-*6T)
8T	SAE-8	(B10-3-*8T)
6B	3/8" BSPG	(B10-3-6B)†
8B	1/2" BSPG	(B10-3-*8B)

* Add "A" for aluminum, omit for steel.
† Steel bodies only.



General Description

Two Position, Three Way Shuttle Valve.
For additional information see Technical Tips on pages SH1-SH2.

Features

- High flow capacity
- Used as automatic brake release valve on motors
- Hardened working parts for maximum durability
- All external parts zinc plated

Performance Curve

Pressure Drop vs. Flow (Through cartridge only)

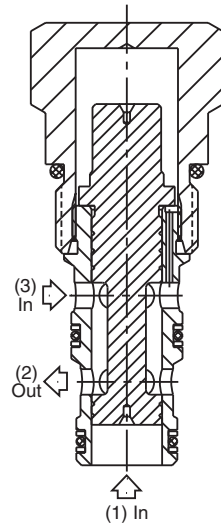
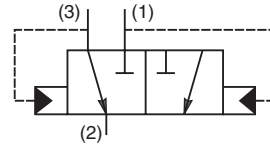
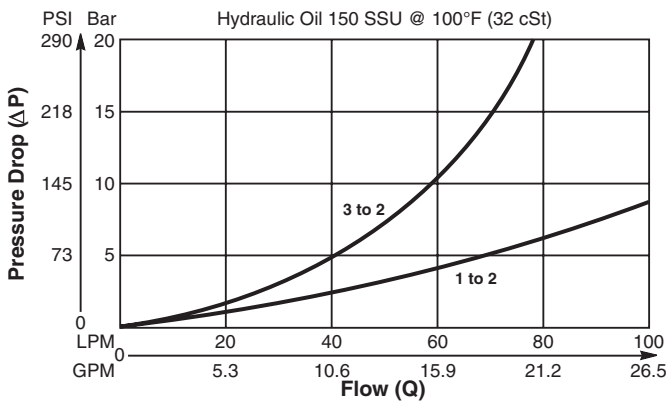

Dimensions Millimeters (Inches)

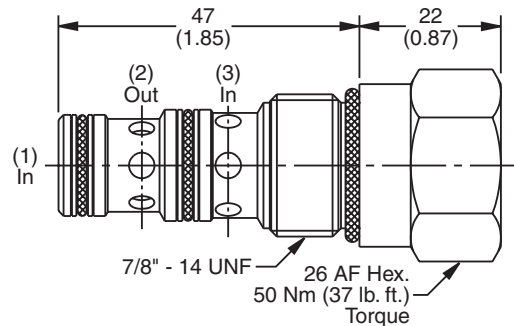

Specifications

Rated Flow	90 LPM (24 GPM)
Nominal Flow @ 7 Bar (100 PSI)	50 LPM (13 GPM)
Maximum Inlet Pressure	420 Bar (6000 PSI)
Cartridge Material	All parts steel. All operating parts hardened steel.
Operating Temp. Range/Seals	-40°C to +93.3°C (Nitrile, Buna-N) (-40°F to +200°F) -31.7°C to +121.1°C (Fluorocarbon) (-25°F to +250°F)
Fluid Compatibility/Viscosity	Mineral-based or synthetic with lubricating properties at viscosities of 45 to 2000 SSU (6 to 420 cSt)
Filtration	ISO code 16/13, SAE Class 4 or better
Approx. Weight	.14 kg (.31 lbs.)
Cavity	C10-3 (See BC Section for more details)

Application

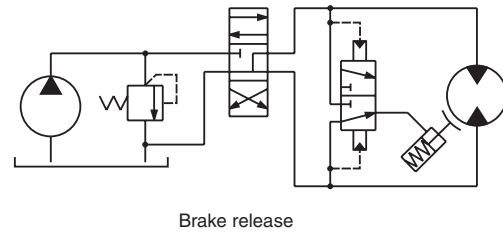

Ordering Information

K04D3	Seals	Body Material	Port Size
Code	Seals / Kit No.	Code	Port Size Body Part No.
N	Nitrile, Buna-N / (SK30505N-1)	Omit	Cartridge Only
V	Fluorocarbon / (SK30505V-1)	4P	1/4" NPTF (B10-3-*4P)
		6P	3/8" NPTF (B10-3-*6P)
		8P	1/2" NPTF (B10-3-*8P)
		6T	SAE-6 (B10-3-*6T)
		8T	SAE-8 (B10-3-*8T)
		6B	3/8" BSPG (B10-3-6B)†
		8B	1/2" BSPG (B10-3-*8B)
Code	Body Material		
Omit	Steel		
A	Aluminum		

* Add "A" for aluminum, omit for steel.
† Steel bodies only.

CV
Check Valves

SH
Shuttle Valves

LM
Load/Motor Controls

FC
Flow Controls

PC
Pressure Controls

LE
Logic Elements

DC
Directional Controls

MV
Manual Valves

SV
Solenoid Valves

PV
Proportional Valves

CE
Coils & Electronics

BC
Bodies & Cavities

TD
Technical Data

Technical Information

- CV** Check Valves
- SH** Shuttle Valves
- LM** Load/Motor Controls
- FC** Flow Controls
- PC** Pressure Controls
- LE** Logic Elements
- DC** Directional Controls
- MV** Manual Valves
- SV** Solenoid Valves
- PV** Proportional Valves
- CE** Coils & Electronics
- BC** Bodies & Cavities
- TD** Technical Data

General Description

Two Position, Three Way, Spring Centered Shuttle Valve. For additional information see Technical Tips on pages SH1-SH2.

Features

- High flow capacity
- Various switching pressures available
- Use as purge valve in transmission systems
- Hardened working parts for maximum durability
- All external parts zinc plated

Performance Curve

Pressure Drop vs. Flow (Through cartridge only)

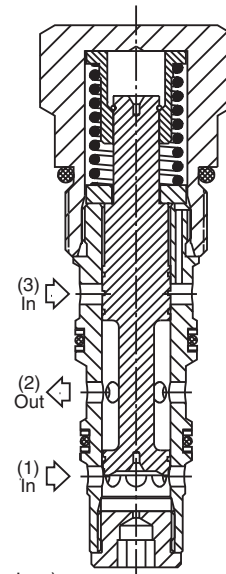
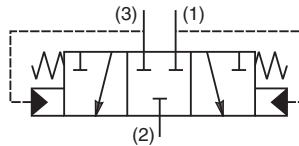
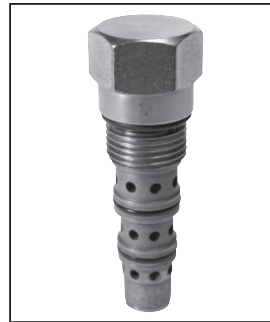
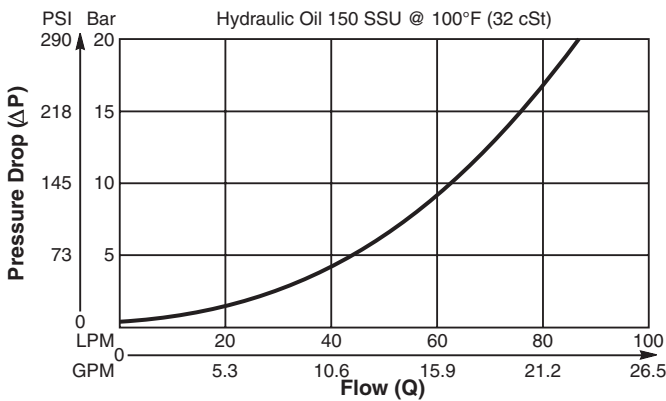

Dimensions Millimeters (Inches)

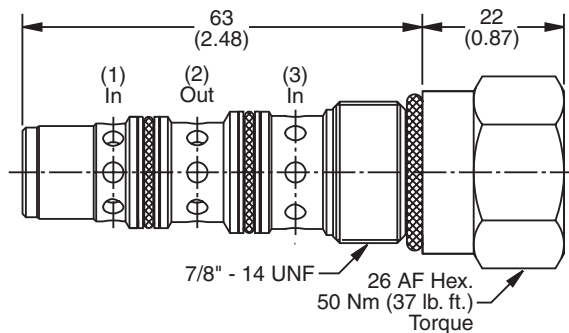

Specifications

Rated Flow	100 LPM (26 GPM)
Nominal Flow @ 7 Bar (100 PSI)	55 LPM (15 GPM)
Maximum Inlet Pressure	420 Bar (6000 PSI)
Cartridge Material	All parts steel. All operating parts hardened steel.
Operating Temp. Range/Seals	-40°C to +93.3°C (Nitrile, Buna-N) (-40°F to +200°F) -31.7°C to +121.1°C (Fluorocarbon) (-25°F to +250°F)
Fluid Compatibility/Viscosity	Mineral-based or synthetic with lubricating properties at viscosities of 45 to 2000 SSU (6 to 420 cSt)
Filtration	ISO code 16/13, SAE Class 4 or better
Approx. Weight	.17 kg (.37 lbs.)
Cavity	C10-4 (See BC Section for more details)

Application

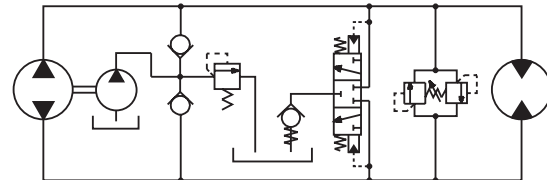

Purge valve in transmission circuit

Ordering Information

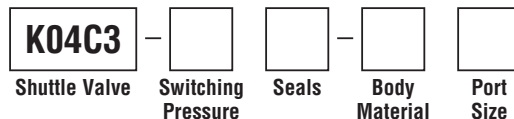

Code	Switching Pressure
0.0	0 Bar (0 PSI)
2.5	2.5 Bar (36 PSI)
5.0	5.0 Bar (73 PSI) Std.
10.0	10.0 Bar (145 PSI)
15.0	15.0 Bar (218 PSI)

Code	Body Material
Omit	Steel
A	Aluminum

Code	Seals / Kit No.
N	Nitrile, Buna-N / (SK30504N-1)
V	Fluorocarbon / (SK30504V-1)

Code	Port Size	Body Part No.
Omit	Cartridge Only	
6P	3/8" NTPF	(B10-4-*6P)
6T	SAE-6	(B10-4-*6T)
8T	SAE-8	(B10-4-*8T)
6B	3/8" BSPG	(B10-4-6B)†

* Add "A" for aluminum, omit for steel.
† Steel bodies only



Technical Information

General Description

Two Position, Three Way, Spring Centered Shuttle Valve. For additional information see Technical Tips on pages SH1-SH2.

Features

- High flow capacity
- Compact cost effective design
- Various spring options available
- Used in transmission systems as purge valve where hydraulic parking brake is necessary
- Hardened working parts for maximum durability
- All external parts zinc plated

Performance Curve

Pressure Drop vs. Flow (Through cartridge only)

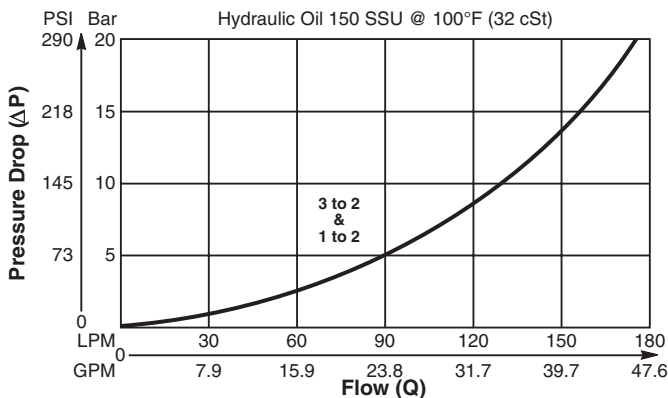

Specifications

Rated Flow	175 LPM (46 GPM)
Nominal Flow @ 7 Bar (100 PSI)	105 LPM (28 GPM)
Maximum Inlet Pressure	350 Bar (5000 PSI)
Cartridge Material	Steel operating parts, hardened steel poppet.
Operating Temp. Range/Seals	-40°C to +93.3°C (Nitrile, Buna-N) (-40°F to +200°F) -31.7°C to +121.1°C (Fluorocarbon) (-25°F to +250°F)
Fluid Compatibility/Viscosity	Mineral-based or synthetic with lubricating properties at viscosities of 45 to 2000 SSU (6 to 420 cSt)
Filtration	ISO code 16/13, SAE Class 4 or better
Approx. Weight	.32 kg (.70 lbs.)
Cavity	3J (See BC Section for more details)

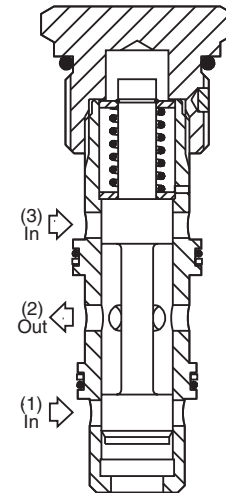
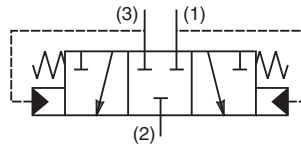
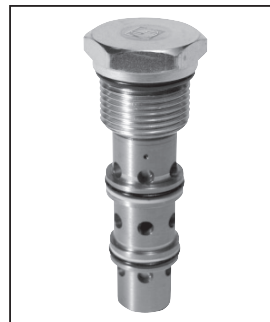

Dimensions Millimeters (Inches)

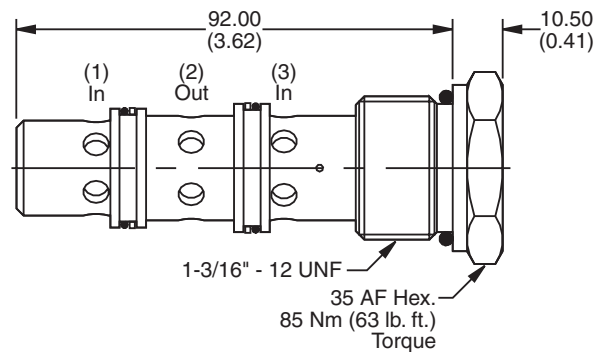

Application

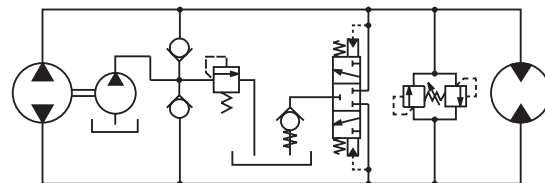

Purge valve in transmissions with hydraulic parking brake

Ordering Information

K3A125 —
Shuttle Valve Switching Pressure Seals

Code	Switching Pressure
1.0	1.0 Bar (15 PSI) Std.
9.0	9.0 Bar (130 PSI)

Code	Seals / Kit No.
N	Nitrile, Buna-N / (SK30040N-1)
V	Fluorocarbon / (SK30040V-1)

Order Bodies Separately

LB10	<input type="checkbox"/>	<input type="checkbox"/>
Line Body	Porting	Body Material

Code	Porting
092	3/4" BSP
093	1" SAE

Code	Body Material
A	Aluminum
S	Steel

CV

Check Valves

SH

Shuttle Valves

LM

Load/Motor Controls

FC

Flow Controls

PC

Pressure Controls

LE

Logic Elements

DC

Directional Controls

MV

Manual Valves

SV

Solenoid Valves

PV

Proportional Valves

CE

Coils & Electronics

BC

Bodies & Cavities

TD

Technical Data

Technical Information

- CV Check Valves
- SH Shuttle Valves
- LM Load/Motor Controls
- FC Flow Controls
- PC Pressure Controls
- LE Logic Elements
- DC Directional Controls
- MV Manual Valves
- SV Solenoid Valves
- PV Proportional Valves
- CE Coils & Electronics
- BC Bodies & Cavities
- TD Technical Data

General Description

Two Position, Three Way, Spring Centered Shuttle Valve. For additional information see Technical Tips on pages SH1-SH2.

Features

- High flow capacity
- Various switching pressures available
- Hardened working parts for maximum durability
- All external parts zinc plated

Performance Curve

Pressure Drop vs. Flow (Through cartridge only)

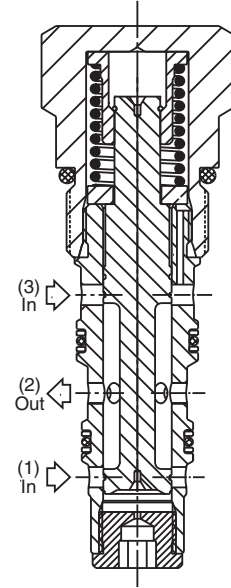
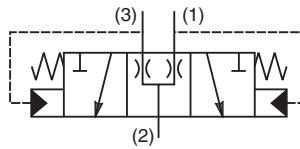
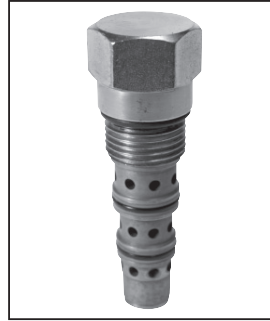
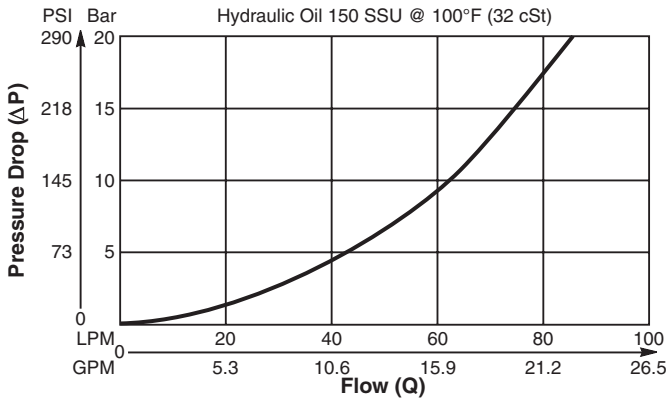

Dimensions Millimeters (Inches)

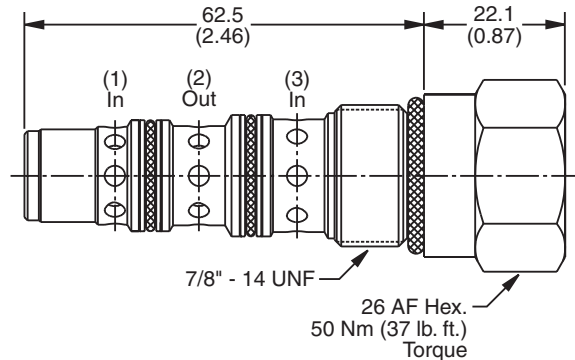

Specifications

Rated Flow	100 LPM (26 GPM)
Nominal Flow @ 7 Bar (100 PSI)	55 LPM (15 GPM)
Maximum Inlet Pressure	420 Bar (6000 PSI)
Cartridge Material	All parts steel. All operating parts hardened steel.
Operating Temp. Range/Seals	-40°C to +93.3°C (Nitrile, Buna-N) (-40°F to +200°F) -31.7°C to +121.1°C (Fluorocarbon) (-25°F to +250°F)
Fluid Compatibility/Viscosity	Mineral-based or synthetic with lubricating properties at viscosities of 45 to 2000 SSU (6 to 420 cSt)
Filtration	ISO code 16/13, SAE Class 4 or better
Approx. Weight	.17 kg (.37 lbs.)
Cavity	C10-4 (See BC Section for more details)

Ordering Information

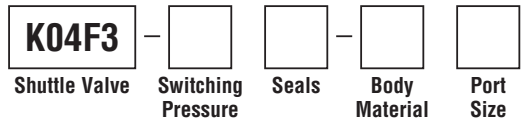

Code	Switching Pressure
0.0	0 Bar (0 PSI)
2.5	2.5 Bar (36 PSI)
5.0	5.0 Bar (73 PSI) Std.
10.0	10.0 Bar (145 PSI)
15.0	15.0 Bar (218 PSI)

Code	Body Material
Omit	Steel
A	Aluminum

Code	Seals / Kit No.
N	Nitrile, Buna-N / (SK30504N-1)
V	Fluorocarbon / (SK30504V-1)

Code	Port Size	Body Part No.
Omit	Cartridge Only	
6P	3/8" NTPF	(B10-4-*6P)
6T	SAE-6	(B10-4-*6T)
8T	SAE-8	(B10-4-*8T)
6B	3/8" BSPG	(B10-4-6B)†

* Add "A" for aluminum, omit for steel.
† Steel bodies only



General Description

Three Way, Ball Type, Spring Centered Inverse Shuttle Valve. For additional information see Technical Tips on pages SH1-SH2.

Features

- Used to ensure that in a dual accumulator charging circuit the accumulator with the lowest pressure is sensed back to the charging valve
- Suitable for charge rates up to 25 LPM (7 GPM) per accumulator
- One size valve for most applications
- All external parts zinc plated

Performance Curve

Pressure Drop vs. Flow (Through cartridge only)

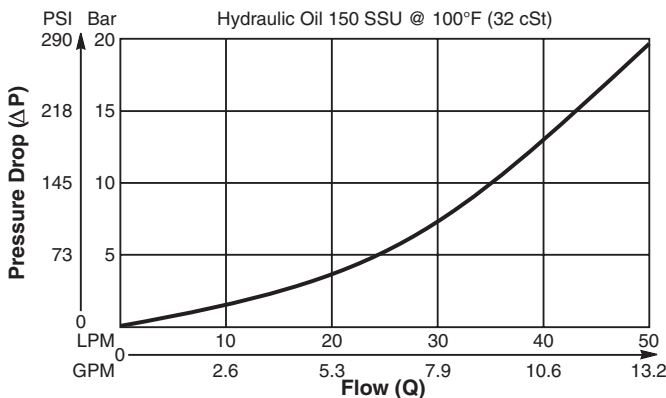

Specifications

Rated Flow	50 LPM (13.2 GPM)
Nominal Flow @ 7 Bar (100 PSI)	30 LPM (7.9 GPM)
Maximum Inlet Pressure	350 Bar (5000 PSI)
Cartridge Material	All parts steel. All operating parts hardened steel.
Operating Temp. Range/Seals	-40°C to +93.3°C (Nitrile, Buna-N) (-40°F to +200°F) -31.7°C to +121.1°C (Fluorocarbon) (-25°F to +250°F)
Fluid Compatibility/Viscosity	Mineral-based or synthetic with lubricating properties at viscosities of 45 to 2000 SSU (6 to 420 cSt)
Filtration	ISO code 16/13, SAE Class 4 or better
Approx. Weight	.14 kg (.31 lbs.)
Cavity	C10-4 (See BC Section for more details)

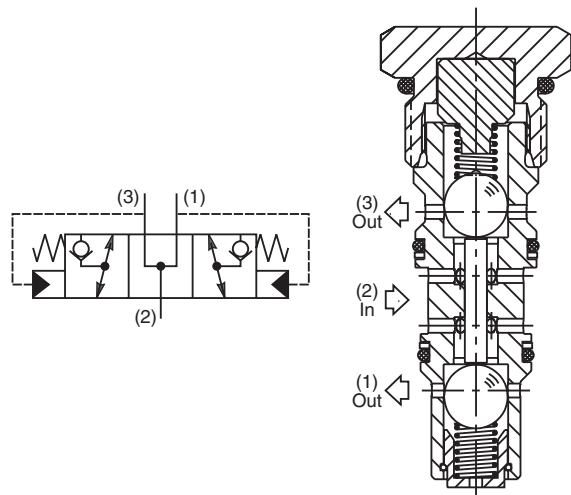

Dimensions Millimeters (Inches)

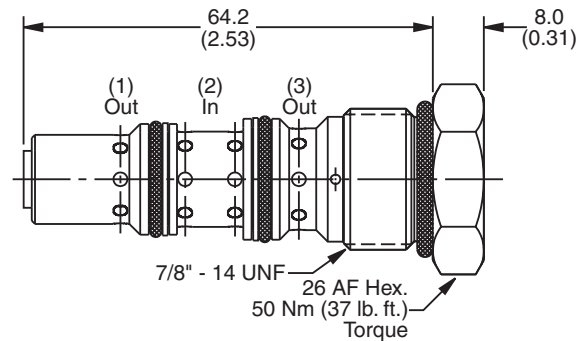

Application

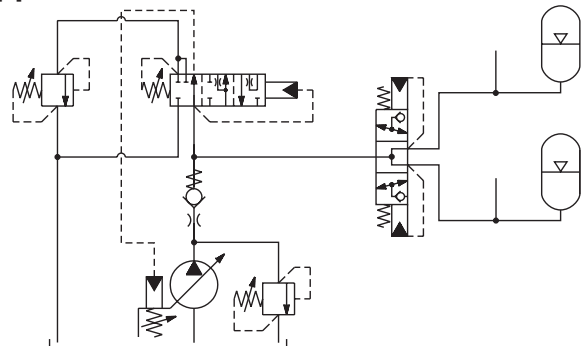

Ordering Information

K04G3	Seals	Body Material	Port Size
Code	Seals / Kit No.	Code	Port Size Body Part No.
N	Nitrile, Buna-N / (SK30534N-1)	Omit	Cartridge Only
V	Fluorocarbon / (SK30534V-1)	6P	3/8" NTPF (B10-4-*6P)
		6T	SAE-6 (B10-4-*6T)
		8T	SAE-8 (B10-4-*8T)
		6B	3/8" BSPG (B10-4-6B)†
Code	Body Material	* Add "A" for aluminum, omit for steel.	
Omit	Steel	† Steel bodies only	
A	Aluminum		

CV

Check Valves

SH

Shuttle Valves

LM

Load/Motor Controls

FC

Flow Controls

PC

Pressure Controls

LE

Logic Elements

DC

Directional Controls

MV

Manual Valves

SV

Solenoid Valves

PV

Proportional Valves

CE

Coils & Electronics

BC

Bodies & Cavities

TD

Technical Data